

Sea Ray Owner's Manual

Sea Ray

185 Sport

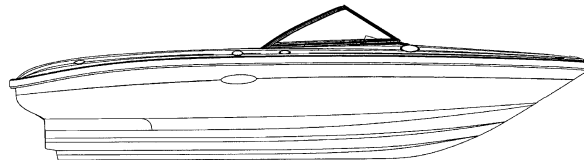

Owner's Manual Part Number: MRP 1769723

WELCOME

Congratulations on becoming the new owner of the world's most prestigious boat. We at Sea Ray® Boats, Inc. welcome you into our worldwide and ever-expanding family of boating enthusiasts.

The Owner's Manual Packet, to be kept on board your Sea Ray, gives you important information on all the features of your Sea Ray, for years of trouble-free boating take the time to carefully review the information in your Owner's Manual Packet and really get to know your boat. **Have everyone who will operate your boat read this manual.**

The Owner's Manual Packet contains the following:

- **Owner's Manual**

The Owner's Manual gives you important operating and safety information, as well as reminding you about your responsibilities as a boat owner/operator.

- **Original Equipment Manufacturer (OEM) Information**

This section of your Owner's Manual Packet contains information from the manufacturers of equipment installed on your boat. Examples include the engine, engine control and steering system. Throughout the Owner's Manual you will be referred to information provided by manufacturers of specific systems.

Because your purchase represents a substantial investment, we know you will want to take the necessary measures to protect its value. We have outlined a program for proper operation, periodic maintenance and safety inspections. We urge you to follow these recommendations. If you have questions which are not fully covered by the Owner's Manual Packet, please consult your authorized dealer for assistance.

Thank You For Selecting A Sea Ray®!

Bon Voyage

Sea Ray





INTRODUCTION

1. THIS MANUAL

The material here and in the rest of the Owner's Manual Packet:

- Gives you basic safety information;
- Describes the features of your boat;
- Describes the equipment on your boat;
- Describes the fundamentals of boat use; and
- Contains service and maintenance information.

You must learn to operate this boat as well as read, understand and use this manual.

What this manual does not give you is a course in boating safety, or how to navigate, anchor or dock your boat. Operating a power boat safely requires more skills, knowledge and awareness than is necessary for a car or truck.

2. YOUR RESPONSIBILITIES

For your safety, the safety of your passengers, other boaters and people in the water, you must:

- Take a boating safety course;
- Get instruction in the safe and proper handling of your boat;
- Understand and follow the "rules of the road";
- Learn how to navigate.

3. SOURCE OF INFORMATION

In North America, contact one of the following for boating courses:

- U.S. Coast Guard Auxiliary
- U.S. Power Squadron
- Canadian Power and Sail Squadrons
- Red cross
- State Boating Offices

- Yacht Club

Contact your dealer or the Boat/U.S. Foundation at 1-800-336-2628

Outside of North America, contact your boat dealer and/or your governmental boating agency for assistance.

A book that provides a comprehensive background in boating is Chapman - Piloting, Seamanship and small Boat handling, by Elbert S. Maloney, published by Hearst Marine.

4. DEALER RESPONSIBILITIES

In addition to a pre-delivery check and service of the boat, your dealer is to give you:

- A description and demonstration of the safety systems, features, instruments and controls on your boat;
- An orientation in the general operation of your boat;
- An "In Service Form" completed by you and the dealer after your inspection of the boat;
- A review of all warranty information and how to obtain warranty service;
- The complete Owner's Manual Packet.

If you do not receive all of these materials, or have any questions, contact your dealer or call 1-800-BOATS.

5. WARRANTIES

Your boat comes with several warranties. Each component and/or system on your boat has its own warranty that will be found with the specific information and manual for that component. These are included with your Owner's Manual Packet. Locate and read the individual warranties; then put them together for easy future reference. The Sea Ray® warranty is on the warranty information card in your packet and is repeated on the next page.



6. HULL IDENTIFICATION NUMBER (HIN)

The "Hull Identification Number" located on the starboard side of the transom, is the most important identifying factor and must be included in all correspondence and orders. Failure to include it creates delays. Also of vital importance are the engine serial numbers and part numbers when writing about or ordering parts for your engine. Refer to the Engine Operator's Manual for locations of engine serial numbers and record them for future reference.

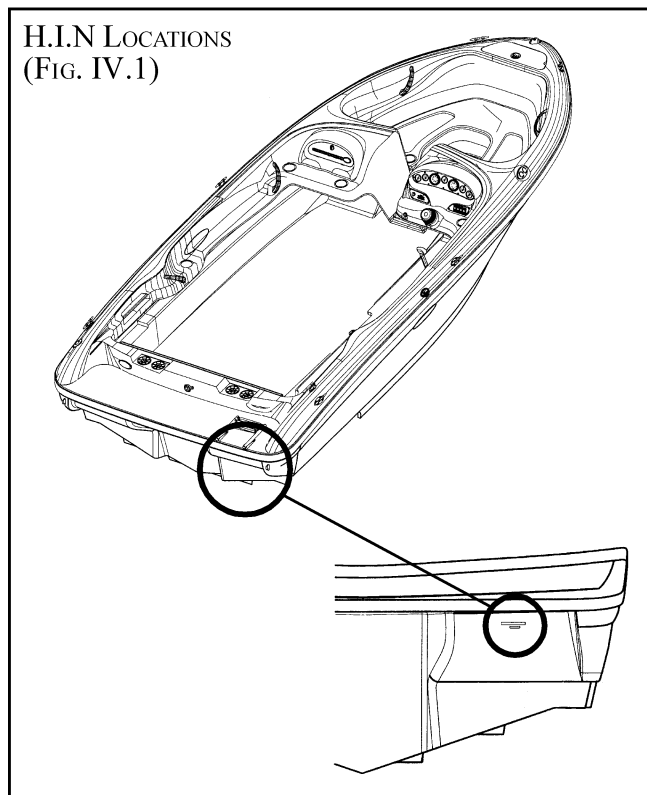

7. MANUFACTURER'S CERTIFICATION

A CE mark means that your Sea Ray® Boat has been certified to meet the applicable International Organization for Standardization directives.

NMMA certification means that your Sea Ray® Boat has been judged by the National Marine Manufacturers Association to be in compliance with applicable federal regulations and American Boat and Yacht Council standards.

Boat Model: _____
Design Category: <input type="checkbox"/> Ocean <input type="checkbox"/> Offshore <input type="checkbox"/> Inshore <input type="checkbox"/> Sheltered Waters
Hull Identification Number: _____
Maximum Recommended Load: _____
Recommended Number of Passengers: _____
Maximum Rated Engine Power: _____
<u>Engine Installed</u>
Manufacturer: _____
Model and Number: _____
<u>Weight of Craft</u>
W/Engine & Permanently Attached Items: _____
Without Engine: _____

The following information is furnished in compliance with ISO directives and RSG guidelines in effect as of the date of publication of this manual. Sea Ray® will provide additional information as standards are amended. The following information, required for export of the vessel, must be filled out by the dealer.

8. SERVICE, PARTS AND REPAIR FOR YOUR BOAT

When your boat needs service, parts or repair, take it to an authorized Sea Ray® dealer. To find a dealer in your area call:

1-800-SRBOATS
Fax: 1-314-213-7878
Domestic/International

To find repair and parts facilities for the equipment installed on your boat, refer to the manual for that component.

If a problem is not handled to your satisfaction:

1. Discuss any warranty-related problems directly with the service manager of the dealership or your sales person. Give the dealer an opportunity to help the service department resolve the matter for you.
2. If a problem arises that has not been resolved to your satisfaction by your dealer, contact Sea Ray® Boats at 1-800-SRBOATS and the appropriate customer service department information will be provided to you.



ABOUT YOUR LIMITED WARRANTY

Sea Ray offers an express limited warranty on each new Sea Ray sport boat purchased through an authorized Sea Ray dealer. A copy of the Sea Ray Sport Boat Limited Warranty (“Limited Warranty”) was included in your owner’s packet. If for any reason, you did not receive a copy of the limited warranty, please contact your local dealer or call 1-800-SRBOATS for a replacement copy. This is a summary of several provisions of the Limited Warranty. Please read the Limited Warranty, which is the controlling document.

Under the Limited Warranty, Sea Ray covers: (a) structural fiberglass deck or hull defects which occur within five (5) years of the date of delivery; (b) parts found to be defective in factory material or workmanship within one (1) year of the date of delivery; (c) laminate blisters resulting from defects in factory material or workmanship for five (5) years on a pro-rated basis.

On Sport Boats, Sea Ray provides additional warranty coverage to its five-year structural hull/deck coverage with a limited life-time structural hull/deck warranty. This limited lifetime structural coverage provides repairs of any Structural Fiberglass Hull/Deck Defect for as long as the original owner owns the Sport Boat. Sport Boat models and Hull/Deck Defects are defined in the Limited Warranty.

Sea Ray’s obligation under its Limited Warranty is limited to repair or replacement of parts that are judged defective by Sea Ray and does not include transportation, haul out, or other expenses. The foregoing is the **sole and exclusive** remedy provided by Sea Ray.

The Limited Warranty does not cover engines, stern drives, controls, propellers, batteries, trailers, or other equipment or accessories carrying their own individual warranties, nor does the Limited Warranty cover engines, parts or

accessories not installed by Sea Ray. The Limited Warranty does not cover cosmetic gel coat finish. Boats used for commercial purpose are excluded from coverage. **See the Limited Warranty for other exclusions.**

SEA RAY EXPRESSLY DISCLAIMS THE IMPLIED WARRANTIES OF FITNESS AND MERCHANTABILITY. NEITHER SEA RAY NOR THE SELLING DEALER SHALL HAVE ANY RESPONSIBILITY FOR LOSS OF USE OF THE BOAT, LOSS OF TIME, INCONVENIENCE, COMMERCIAL LOSS OR CONSEQUENTIAL DAMAGES.

The unexpired term on the limited one-year parts and components coverage and the limited five-year pro-rated blister coverage of the Limited Warranty may be transferred to a subsequent owner upon the new owner’s written request. Coverage for Structural Fiberglass Hull/Deck Defects on Sport Boats may be transferred once to a second owner upon the second owner’s request, however upon transfer, this coverage will expire ten (10) years from the date of original purchase by the first retail owner, as reflected in Sea Ray’s records.

The new owner can submit a request for warranty transfer, free of charge, via the searay.com website. Alternatively, the new owner can submit a written request to the Sea Ray Division of Brunswick Corporation, 2600 Sea Ray Blvd., Knoxville, TN 37914, accompanied by a \$50 processing fee.

Thank you for your decision to buy a Sea Ray.

The Limited Warranty is subject to change at any time at Sea Ray’s discretion. The information contained herein is general information about the Limited Warranty for the owner’s general knowledge, and does not alter or amend the terms of the Limited Warranty.



185 SPORT OWNER'S MANUAL • TABLE OF CONTENTS

INTRODUCTION

1. This Manual	iii
2. Your responsibilities	iii
3. Source of Information	iii
4. Dealer Responsibilities	iii
5. Warranties	iii
6. Hull Identification Number (HIN)	iv
7. Manufacturer's Certification	iv
8. Service, Parts and Repair for Your Boat	iv
9. Express Limited Transferable Warranty	v

SECTION 1 • SAFETY

1. Safety Labels	1.1
2. Legally Mandated Minimum Required Equipment ..	1.2
3. Fire Extinguishing Equipment	1.2
4. Carbon Monoxide	1.2
A. Carbon Monoxide Monitors	1.3
5. Life Saving Equipment	1.3
A. PFD Classifications	1.4
6. Additional Recommended Equipment for Safe Operation	1.5
7. Impaired Operation	1.5
8. Load Capacity	1.5
9. Power Capacity	1.6
10. Stability	1.7
11. Maintain Control	1.7
A. General Considerations	1.7
12. Weather	1.8
A. Ocean	1.8
B. Offshore	1.8
C. Inshore	1.8
D. Sheltered Waters	1.8
13. Chart Your Course	1.9
14. Water Sports	1.9
A. Swimming	1.9
B. Skiing	1.10
C. Diving	1.10
15. Emergency Situations	1.11
A. Medical Emergency	1.11
B. Water Rescue	1.11
C. Fire	1.11
D. Flooding, Swamping and Capsizing	1.12
E. Collisions and Leaking	1.12
F. Grounding	1.12
G. Propulsion, Control or Steering Failure	1.12
16. Safety Hotlines	1.13
17. International Requirements	1.13
18. Nautical Terms	1.13
19. Key to Symbols on Control & Prints	1.15
20. Warning Label Locations	1.17

SECTION 2 • GENERAL BOAT ARRANGEMENT

1. Docking/Lifting/Trailing	2.1
2. Passenger Locations	2.1
3. Propulsion System	2.2
4. Basic Boat Dimensions and Clearances	2.3
5. Propellers	2.3
6. General Deck Layout	2.4
7. Helm Gauge and Switch Layout	2.7
8. Function and Location of Thru-Hull Cutouts	2.8
9. Description of Major Controls	2.8
A. Gear Shift and Throttle Control	2.8
B. Power Trim Unit and Gauge	2.9
C. Trailer Switch	2.9
D. Ignition Shutdown Switch (Standard on Side Mount Controls)	2.10
E. Engine Alarm System (Only on Certain Engines)	2.10
11. Important Gauges	2.11
A. Tachometer and Hourmeter	2.11
B. Oil Pressure, Water Temperature and Fuel Gauge	2.11
12. Navigation and Anchor Light	2.11

SECTION 3 • USING YOUR BOAT

1. Pre-Launch, Launch and Post-Launch Checklist ...	3.1
2. Trailer Launching and Loading	3.2
3. Fueling the Boat	3.2
4. Boarding	3.3
5. Personal Flotation Devices (PFDs)	3.4
6. Passenger Instruction and Location	3.4
7. Starting the Engines	3.4
8. Shifting to Drive the Boat	3.6
9. Stopping the Engines	3.6
10. Steering System	3.6

SECTION 4 • BILGE & UNDERWATER GEAR

1. Bilge	4.1
A. Fuel & Oil Spillage	4.1
B. Drain Plug	4.1
C. Bilge Pump	4.1
D. Bilge Blower	4.2
E. Engine and Stern Drive	4.3
F. Bilge Layout	4.5



185 SPORT OWNER'S MANUAL • TABLE OF CONTENTS

SECTION 5 • FUEL SYSTEM

- 1. Fuel System 5.1
 - A. Anti-Siphon Valve
(Inboard/Outboard Engine Only) 5.1
- 2. Fueling Precautions 5.2
 - A. General 5.2
 - B. Before & During Fueling - Checklist 5.2
 - C. After Fueling - Checklist 5.2

SECTION 6 • ELECTRICAL SYSTEM

- 1. Electrical System 6.1
 - A. Direct Current (DC) 6.1
 - B. Battery Switch 6.3
- 2. Ignition Protection 6.3
- 3. Fuses 6.4
- 4. 12 Volt Accessory Receptacle 6.5
- 5. Lighting 6.5
- 6. Electrolytic Corrosion and Zinc Anodes 6.6
- 7. Wire Harnesses 6.7
- 8. Electrical Schematics 6.9

SECTION 7 • OPTIONS & ACCESSORIES

- 1. Boat Layout and Accessory Locations 7.1
- 2. Canvas 7.1
 - A. Installation Tips 7.2
 - B. Trailering with canvas 7.2
 - C. Canvas Care and Maintenance 7.2

SECTION 8 • REQUIRED INSPECTION, SERVICE AND MAINTENANCE

- 1. Summary Guide for Inspection, Service and Maintenance 8.1
- 2. Inspection, Service and Maintenance Protocol 8.3
 - A. Bilge Area 8.3
 - B. Topside and Supplies 8.4
- 3. Winterization Checklist for Boats Stored on Land .. 8.4
 - A. Boat Storage 8.4
 - B. Engines 8.4
 - C. Battery(ies) 8.4
 - D. Fuel System 8.4
- 4. Fitting Out After Storage 8.5
 - A. Fuel System 8.5
 - B. Battery(ies) 8.5
 - C. Miscellaneous 8.5
- 5. Security Considerations 8.5
- 6. Power Steering System Maintenance 8.5

SECTION 9 • CARE & REFINISHING

- 1. Paint, Cleaning Agents and Other Substances 9.1
- 2. Fiberglass & Gelcoat 9.1
- 3. Stains & Scratches 9.1
- 4. Permanently Moored or Docked Boats 9.2
- 5. Care for Bottom Paint 9.2
- 6. Topside Areas 9.2
 - A. Stainless Steel and Alloy Fittings 9.2
 - B. Salt Crystals 9.2
- 7. Acrylic Plastic Sheeting (Plastic Glass) 9.2
- 8. Canvas and Clear Vinyl 9.2
- 9. Exterior Upholstery Fabric 9.3

Information in this publication is based upon the latest product specifications available at printing. Sea Ray® Boats, Inc. reserves the right to make changes at any time, without notice, in the colors, equipment, specifications, materials and prices of all models, or to discontinue models. Should changes in production models be made, Sea Ray® is not obligated to make similar changes or modifications to models sold prior to the date of such changes.

185 Sport Owner's Manual
Printed in the U.S.A February 2001
Revised: September 2002, June 2003, May 2004
© Sea Ray Boats, Inc. • A Brunswick Company
MRP #1769723

Sea Ray Boats, Inc. 2600 Sea Ray Blvd., Knoxville, TN 37914
For information call 1-800-SRBOATS or fax 1-314-213-7878
Internet Address: <http://www.searay.com>

Note: Not all accessories shown in pictures or described herein are standard equipment or even available as options. Options and features are subject to change without notice.

The following are registered trademarks of the Brunswick Corporation: Sea Ray® & The SR Wave Logo



THIS PAGE LEFT INTENTIONALLY BLANK



SECTION 1 • SAFETY

SAFE boating means:

- Knowing the limitations of your boat;
- Following the rules of the road;
- Keeping a sharp lookout for people and objects in the water;
- Not boating in water or weather conditions that are beyond the boat's and the operator's capability;
- Never boating when the operator is under the influence of drugs or alcohol;
- Being aware of your passenger's safety at all times; and
- Reducing speed when there is limited visibility, rough water, nearby people in the water, boats, or structures.

Boating in beautiful weather and calm water conditions can be a wonderful experience. Pleasurable boating, however, requires considerably greater skills than operating a land vehicle. To obtain these skills, you must:

- Take a Coast Guard, U.S. Power Squadron or equivalent boating safety course. **Call the Boat/U.S. Foundation at 1-800-336-2628 for information on available courses.**
- Get hands-on training on how to operate your boat properly.

In addition:

- Maintain your boat and its safety and other systems as recommended in this manual.
- Have the boat inspected by a qualified mechanic or dealer, at least annually.
- Ensure that the Coast Guard required safety equipment is on board and functions. (See page 1.3).

1. SAFETY LABELS

Safety precautions are given throughout this manual and labels are mounted at key locations throughout the boat. This safety information advises the owner/operator and passengers of imperative safety precautions to follow when operating and/or servicing equipment. engine serial numbers and part numbers when writing about or ordering parts for your engine. Refer to the Engine Operator's Manual for locations of engine serial numbers and record them for future reference.

- Figure 1.17.1 shows the location of the safety labels on your boat.
- Do not remove or obstruct any safety label.
- Replace any label which becomes illegible. Replacement safety labels can be obtained by calling your dealer or Sea Ray at 1-800-SRBOATS for information on how to contact the manufacturing facility for your boat.

The meaning associated with each of the four basic types of label is:

DANGER

DANGER – Immediate hazards which **WILL** result in severe personal injury or death if the warning is ignored.

WARNING

WARNING – Hazards or unsafe practices which **COULD** result in severe personal injury or death if the warning is ignored.

CAUTION

CAUTION – Hazards or unsafe practices which could result in minor injury or product or property damage if the warning is ignored.

NOTICE

Information which is important to proper operation or maintenance, but is not hazard-related.



SECTION 1 • SAFETY

2. LEGALLY MANDATED MINIMUM REQUIRED EQUIPMENT

Consult your national boating law enforcement agency.

The following equipment is the minimum required by the U.S. Coast Guard for a boat less than 26' [7.9 meters] in length.

Personal Flotation Devices (PFD's): One Coast Guard approved Type I, II or LLL device is mandatory for each person aboard. One throwable Type LV device is also required to be on board. A Type V device is acceptable if worn for approved use. See Page 1.5 for a description of these PFD classifications. **Always wear a PFD when boating.**

Fire Extinguisher - Portable: If no fixed fire extinguishing system is installed in the engine and generator spaces, the U.S. Coast Guard requires **one (1) Type B-1** fire extinguisher be on board. The American Boat and Yacht Council (ABYC) recommends that you have **two (2) Type ABC** fire extinguishers on board. One is to be located at the helm station and the other in the cabin, near the cockpit door.

Whistle, Horn: You must have on board some means of making a loud sound signal, for example, whistle or horn.

Visual Distress Signals: If you operate your boat in coastal waters or on the Great Lakes, you must have visual distress signals for day and night use on board. At least three (3) U.S. Coast Guard approved pyrotechnic devices marked with date showing service life must be carried, be readily accessible, in serviceable condition and not expired. Store pyrotechnic signals in a well-marked waterproof container in a dry location.

Other: Your Sea Ray is equipped with the required navigation lights, engine exhaust and ventilation systems.

3. FIRE EXTINGUISHING SYSTEM

Your boat is equipped with an automatic fire extinguisher system. Located in the engine compartment. In the event of a fire, the heat sensitive automatic head in the engine compartment will release a fire-extinguishing vapor, totally flooding the area.

The dashboard contains an indicator light for the automatic fire extinguishing system. The light will be ON when the ignition is on and indicates that the system is ready. If the light goes out while the ignition is on, the system has discharged.

WHEN DISCHARGE OCCURS, IMMEDIATELY SHUT DOWN ALL ENGINES, POWERED VENTILATION, ELECTRICAL SYSTEMS AND EXTINGUISH ALL SMOKING MATERIALS. DO NOT IMMEDIATELY OPEN THE ENGINE COMPARTMENT!! THIS FEEDS OXYGEN TO THE FIRE AND THE FIRE COULD RESTART.

Wait at least fifteen (15) minutes before opening the engine compartment. This permits the fire-extinguishing vapor to "soak" the compartment long enough for hot metals and fuels to cool. Have portable extinguishers at hand and ready to use in case the fire reignites. Do not breathe fumes or vapors caused by the fire.

4. CARBON MONOXIDE

Symptoms of carbon monoxide poisoning are dizziness, ears ringing, headaches, nausea and unconsciousness. A poisoning victim's skin often

DANGER

Fumes from engine, generators, and other equipment and appliances using burning fuel contain carbon monoxide.

Carbon Monoxide can kill you.

Open all doors, curtains, windows, and hatches to let fresh air circulate, when running engine, generator or burning any fuel when boat is anchored, moored or docked.



SECTION 1 • SAFETY

⚠ DANGER

Even in rainy cold weather ventilation must be maintained to avoid Carbon Monoxide poisoning. You will get wet and/or cold.

⚠ DANGER

Sleeping on boat requires a operating Carbon Monoxide detection system in each sleeping location.

turns cherry red. Because carbon monoxide gas (CO) is odorless, colorless and tasteless, it is unlikely to be noticed until a person is overcome.

Dangerous concentrations of carbon monoxide will be present if:

- the engine and/or generator exhaust systems leak;
- insufficient fresh air is circulating where people are present; and
- fumes move from the rear of the boat into the cockpit and cabin area.

Figure 1.4.1 gives examples of boat operating conditions that can lead to high concentrations of carbon monoxide gas.

To minimize the danger of CO accumulation when the engine and/or generator are running, or using burning fuel applications.

- Be sure to have sufficient ventilation when using canvas or window-type side curtains when underway, anchored, moored or docked.
- If the convertible top is installed, operate with the forward hatch open and leave cabin door open.
- Operate all burning fuel appliances, such as charcoal, propane, LPG, CNG or alcohol cooking devices in areas where fresh air can circulate. Do not use such devices where there is no noticeable air movement, especially in the cabin, when anchored, moored or docked.

- Do not idle engine without moving boat for more than 15 minutes at a time.
- Inspect the exhaust system regularly. (See Section 8, Required Inspection, Service and Maintenance.

If CO poisoning is suspected, have the victim breath fresh air deeply. If breathing stops, resuscitate. A victim often revives, then relapses because organs are damaged by lack of oxygen. Seek immediate medical attention.

A. CARBON MONOXIDE MONITOR

Your boat has carbon monoxide (CO) monitors mounted throughout the boat. The CO monitor is an electronic instrument that detects CO. When there is a buildup of CO, the monitor will alert the occupants by a flashing DANGER light and alarm. The CO monitor is wired through a breaker on the DC distribution panel.

It is extremely important that you become totally familiar with your CO monitor and its functions.

Read and understand the CO monitor information and operating instructions located in your Owner's Manual Packet.

5. LIFESAVING EQUIPMENT

Even strong swimmers can tire quickly in the water and drown due to exhaustion, hypothermia, or both. The buoyancy provided by a personal flotation device (PFD) will allow the person who has fallen overboard to remain afloat with far less effort and heat loss, extending survival time necessary to find and retrieve them.

Boat operators are required to carry one wearable personal flotation device (Type I, II, III or V) for every person on board. Boats must also have at least one throwable device (Type IV).

The law requires that PFD's must be readily accessible, if not worn. "Readily accessible" means removed from storage bags and unbuckled. But,



SECTION 1 • SAFETY

EXAMPLES OF HOW HIGH LEVELS OF CARBON MONOXIDE MAY ACCUMULATE (FIG. 1.4.1)

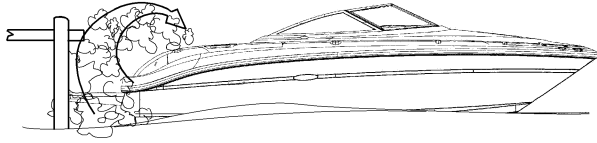

BLOCKING HULL EXHAUSTS. OPERATING AT SLOW SPEED OR DEAD IN THE WATER. ILLUSTRATION #A

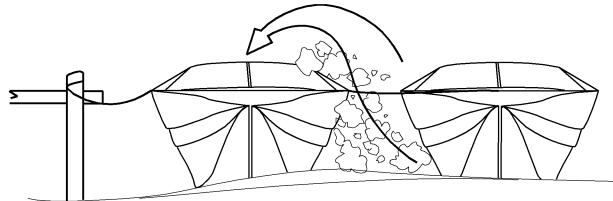

OPERATING ENGINE AND/OR GENERATOR IN CONFINED SPACES. ILLUSTRATION #D

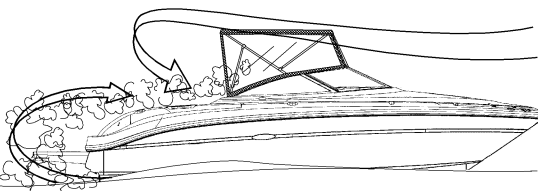

USING CANVAS CURTAINS. ILLUSTRATION #B

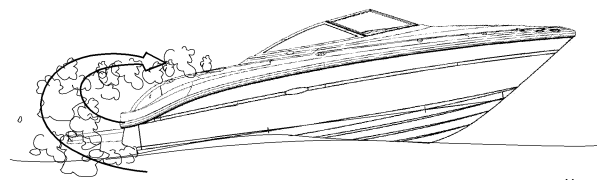

OPERATING WITH THE BOW HIGH. ILLUSTRATION #E

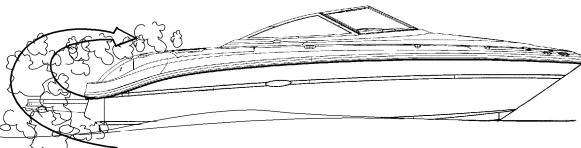

WINDS BLOWING EXHAUST TOWARD BOAT OCCUPANTS. ILLUSTRATION #C

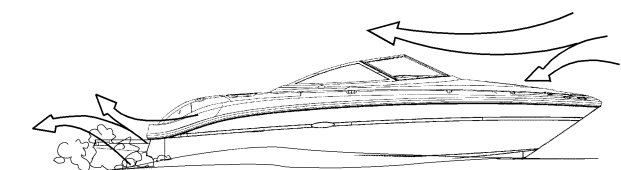

GOOD VENTILATION. ILLUSTRATION #F

children and nonswimmers must wear PFDs at all times when aboard. It is common sense to have everyone on board wearing PFDs. A throwable device must also be right at hand and ready to toss.

A. PFD CLASSIFICATIONS

(FIG. 1.4.2)



Off-Shore Life Jacket (Type I) – most buoyant, it is designed to turn an unconscious person face up; used in all types of waters where rescue may be slow, particularly in cold or rough conditions.

(FIG. 1.4.3)

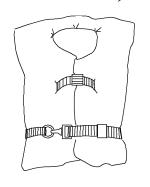

Near-Shore Life Vest (Type II) – “keyhole” vest with flotation-filled head and neck support is also designed to turn a person face up, but the turning action is not as pronounced; used in calm, inland waters or where quick rescue is likely.

(FIG. 1.4.4)

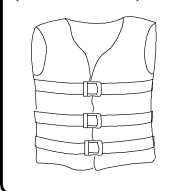

Flotation Aid (Type III) – vest is designed so conscious wearers can turn face up; often designed for comfort while engaged in sports such as skiing.

(FIG. 1.4.5)

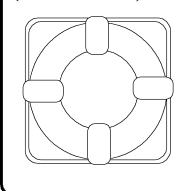

Throwable Devices (Type IV) – horseshoe buoys, ring buoys and buoyant cushions are designed to be grasped, not worn.

(FIG. 1.4.6)

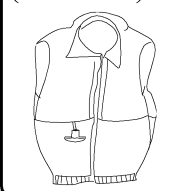

Special-Use Devices (Type V) – sailboat harnesses, white-water vests, float coats, and hybrid vests which have minimum inherent buoyancy and an inflatable chamber.



SECTION 1 • SAFETY

Before purchasing PFDs, ensure that there is an attached tag indicating they are approved by the U.S. Coast Guard or by your national boating law enforcement agency.

Children and nonswimmers must wear PFDs at all times when aboard. All passengers and crew should wear them. A loose PFD is often useless in an emergency.

The operator is responsible for instructing everyone aboard on the location and use of PFDs.

Size PFDs for the wearer. Children require special attention in the use of PFDs.

Test PFD buoyancy at least once a year.

6. ADDITIONAL RECOMMENDED EQUIPMENT FOR SAFE OPERATION

In addition to legally mandated equipment, the following items are necessary for safe boating, especially if your boat is out of sight of land.

- First aid kit
- Visual distress signals for day and night use (required in some areas; consult local regulations)
- Charts of your intended cruising area
- Compass
- GPS or Loran position locating devices
- Marine VHF radio with weather channels
- Emergency position-indicating radio beacon (EPIRB)
- Manual bilge pump
- Moisture repellent
- Anchors, chain and line (The anchors must be properly sized for your boat. Ask your dealer or marine supply store for recommendations).
- Mooring lines
- Fenders
- Boat hook

- Waterproof flashlight(s)
- Extra batteries for flashlights and portable electronic devices
- High power spotlight, if you intend to boat at night
- Spare keys
- Instruction manuals for engine and accessories
- Lubricating oil
- Tool kit:
 - Assorted screwdrivers (Phillips and flat blade)
 - Pliers (regular, vise-grip, and tongue & groove)
 - Wrenches (box, open-end, allen, adjustable)
 - Socket set (metric or U.S. Standard as appropriate)
 - Electrical tape and duct tape
 - Hammer
 - Utility Knife
- Spare parts kit (spark plugs, fuses, hose clamps and ask your dealer to recommend other parts)
- Extra propeller

7. IMPAIRED OPERATION

Drugs and/or alcohol will prevent you from operating your boat safely. This single factor is involved in more marine accidents and deaths than any other. The detrimental effects of alcohol and drugs are increased by the wind, waves and sun, quickly impairing your ability to react properly and promptly in an emergency.

WARNING

Drugs and/or alcohol impair the operator's ability to control the boat safely.

Death or serious injury can result from improper boat operation.

8. LOAD CAPACITY

The certification plate (See fig. 1.6.1 & 1.6.2) located near the helm indicates maximum weight and number of persons your boat can handle under calm sea conditions. **Do not exceed the load capacities**



SECTION 1 • SAFETY

stated. The number of people on board must be reduced if you go out in poor weather and rough water.

The information present on the certification plate does not relieve the operator from responsibility. Use common sense and sound judgement when placing equipment and/or passengers in your boat.

- Donot load to capacity in poor weather or rough water.

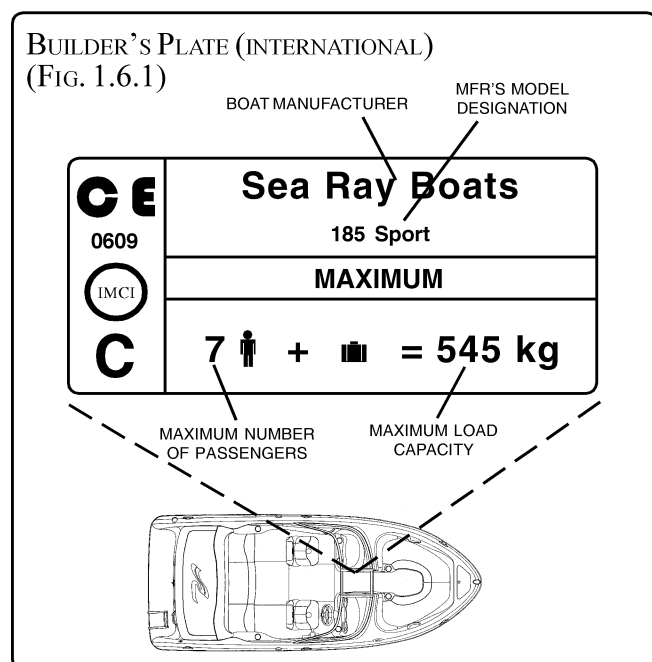

BUILDER'S PLATE (DOMESTIC)
(FIG. 1.6.2)

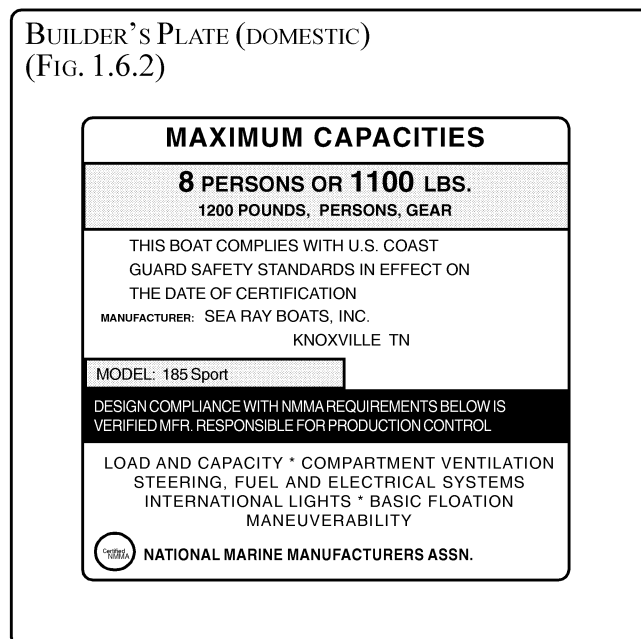

- The number of seats does not indicate how many people a boat can carry in poor weather and rough water.
- Above idle speed, all passengers must be seated on the seats provided.

9. POWER CAPACITY

Do not exceed the maximum engine power rating stated on the certification plate. Your boat will be difficult to handle and will be less stable.

Your Sea Ray® has been equipped with a propeller which our tests have shown to be the best suited for general use with our engine under normal conditions and load. Do not change the pitch of your propeller without getting your dealer's recommendations first. If you change to a different propeller pitch, **under no circumstances use a propeller which allows the engine to operate at higher than recommended RPM.** (your engine manual specifies the maximum recommended (RPM)).

To maintain rated power, propellers should be free of nicks, excessive pitting and any distortions that alter them from their original design. Badly damaged propellers should be replaced, but those that are

! WARNING

When engine is running, keep passengers away from areas not designed for riding, such as seat backs, bow, gunwales, transom platform, swim platform, front and rear decks and on sun pads.

Passengers can fall overboard if not seated properly on the seats provided.

! DANGER

Never carry more weight or passengers than indicated on the certification plate, regardless of weather or water conditions.

The boat can capsize, swamp or sink.



SECTION 1 • SAFETY

chipped, bent or merely out of shape can be reconditioned by your marine dealer.

It is advisable to carry an extra propeller aboard in case you damage the one in use.

10. STABILITY

Your boat was manufactured to specific stability and flotation standards for the capacity shown on the certification plate. Any increase from the recommended load capacities will put your boat in jeopardy of capsizing, swamping and/or sinking.

IN ADDITION:

- Stability may be substantially reduced if equipment is added above the deck.
- Stability is substantially reduced by loose fluids or weight within the hull. Keep bilge area as dry as possible, and close all openings, hatches and windows in rough weather.

WARNING

Distribute passengers and gear as uniformly as possible from front to rear and left to right.

The manufacturer's load rating is the maximum allowed under calm conditions.

Reduce boat loading if weather, water or other conditions are adverse.

11. MAINTAIN CONTROL

On the water there are no marked traffic lanes, no traffic signs or lights, and boats have no turn signals. The boat operator must keep her or his attention focused not only on what's ahead but what's on the left, right and behind the boat.

The operator must always be alert to approaching boats (from the rear, right and left sides, as well as those ahead). There can be people in the water, partially submerged debris, and other navigational hazards such as rocks, sand bars, dangerous currents, to name a few.

Your passengers are relying on you to operate and maneuver the boat safely so that they are not in danger of going overboard. If you turn to quickly, increase or decrease speed abruptly, your passengers are at risk of being thrown overboard or thrown about the boat.

When visibility becomes impaired because of weather, time of day or high bow angle you must slow down so that you have sufficient time to react if an emergency occurs. Nearby boats face similar risks in avoiding a collision with you.

WARNING

Death or serious injury can result if you fail to observe these safety rules:

- **Anyone who controls the boat must have taken a boating safety course and have trained in the proper operation of the boat.**
- **Always operate the boat at speeds that will not put people or property in danger.**
- **Be constantly aware of conditions in all directions when underway and before turning.**
- **Reduce speed, use a lookout to identify possible hazards or difficulties, and turn on navigation lights when:**
 - visibility is impaired;
 - in rough water; and
 - in congested waterways.
- **Watch your wake. It can capsize a small boat or damage moored boats or other property. You are responsible for damage caused by your wake.**

A. GENERAL CONSIDERATIONS

- Know how your boat handles under different conditions. Recognize your limitations and the boat's limitations. Modify speed in keeping with weather, sea and traffic conditions.



SECTION 1 • SAFETY

- Instruct passengers on location and use of safety equipment and procedures.
- Instruct passengers on the fundamentals of operating your boat in case you are unable to do so.
- You are responsible for passenger's actions. If they place themselves or the boat in danger, immediately correct them.

Observe the safety rules listed below.

12. WEATHER

There are four design categories of boats based upon their ability to withstand wind and sea or water conditions:

A. Ocean

Wind speed: above 40 knots (46 mph)
Wave height: above 4 meters (13 feet)
Boat may be used for extended ocean voyages.

B. Offshore

Maximum wind speed: 40 knots (46 mph)
Maximum wave height: 4 meters (13 feet)
Boat can be used offshore, but not for extended ocean voyages.

C. Inshore

Maximum wind speed: 27 knots (31 mph)
Maximum wave height: 2 meters (6.5 feet)
Boat use is limited to coastal waters, large bays, estuaries, lakes and rivers.

D. Sheltered waters

Maximum wind speed: 15 knots (18 mph)
Maximum wave height: 0.5 meters (1.5 feet)
Boat use is limited to small lakes, rivers and canals.

Your 185 Sport is Design Category C.

The wind speed and wave height specified as the upper limit for your category of boat does **not** mean that you or your passengers can survive if your boat is exposed to these conditions. It is only the most experienced operators and crew that may be able

to operate a boat safely under these conditions. You must always be aware of weather conditions and head for port or protected waters in sufficient time to avoid being caught in high winds and rough water. **Do not take chances!**

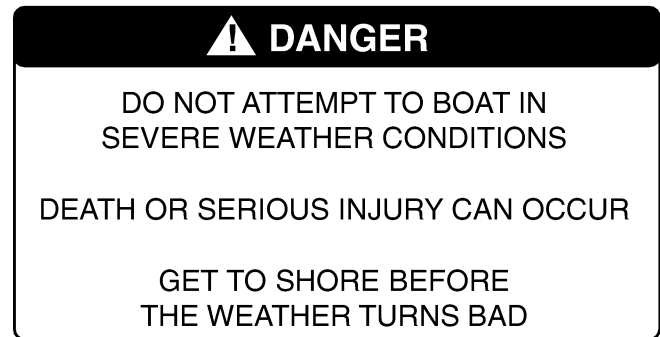

Getting caught in severe weather is hazardous. Bad weather and/or rough sea or water conditions can cause an unsafe situation. Consult local weather information, or listen to the NOAA weather reports for the latest weather conditions or any impending deterioration of the weather before setting out and while underway. Following are a few basic weather-related rules:

- Check the weather forecast and the water conditions before leaving and while underway.
- A sudden change in wind direction or speed or an increase in wave height indicates deteriorating weather.
- Have everyone wear a personal flotation device.
- If a storm approaches, immediately seek a safe harbor.
- If a storm hits, have everyone sit in the cabin or on the cockpit deck in the boat. Head the bow into the wind with enough power to maintain slow headway.
- If you encounter fog, determine your position, set a safe course, slow down and alert other boats of your presence with a sound signal.
- If a lightning storm approaches, the safest action is to dock and disembark. If you cannot return to shore, have passengers go **inside** the cabin and remain there until the storm passes.



SECTION 1 • SAFETY

- Lightning seeks a ground when it strikes. The best protection is a properly grounded lightning rod placed high enough over the deck to provide a protective umbrella over the hull. Depending upon the likelihood of your being in a lightning storm, consult your dealer for installation of a lightning rod. Stay clear of the lightning rod, all attached wiring and all metal parts of the boat.
- Stay out of the water during a lightning storm. If caught swimming during a storm, get back into the boat and remain there until the storm passes.

13. CHART YOUR COURSE

WARNING

Hitting an object in or under the water or boating in dangerous currents can cause serious injury or death to boat occupants.

You must know where the hazards are and avoid them.

In uncharted waters, boat very slowly and post a lookout.

To avoid boating in unsafe areas where there are underwater obstructions, shallow water, unnavigable conditions such as dangerous currents, and others, **you must chart a course.** This means having and using the National Oceanic and Atmospheric Administration (NOAA) charts for coastal waters, observing and understanding all navigational aids, using the knowledge and guidance of experienced boaters, and being aware of the tide times where appropriate.

WARNING

Shut engine off if an object is struck or if you run aground.

Check for hull leaks and drive line damage, before restarting engines.

Use hand pump if bilge pumps don't remove water.

Boat very slowly, if you must proceed with a damaged drive line.

If you are in an unfamiliar area without knowledge of the hazards, proceed very slowly and have someone watch for hazards.

Let others know where you are going. A float plan describes your intended cruising course and itinerary, boat description, and your expected time and date of return. Give the float plan to a friend or relative, so they can give the information to a national boat agency, like the U.S. Coast Guard, in the event you fail to return.

14. WATER SPORTS

WARNING

Your boat can kill or injure persons in the water.

Always stay away from areas designated for swimming or diving. Unless you are towing a skier, stay away from water ski areas. Recognize markers used for such areas.

When engine is running, close and lock transom door and do not permit anyone to use boarding ladder and swim platform.

A. SWIMMING

- Do not permit anyone to swim from a moving boat, or a boat with an engine running.
- Many localities prohibit swimming from boats except in designated areas.
- Make sure boat's engines are turned off before allowing people to swim anywhere near your boat. Shut the engine OFF and remove the key from the ignition switch so that nobody will accidentally start the engine while swimmers are nearby.
- Turn off engines when taking swimmers or skiers aboard or when they are entering the water. Never permit use of the transom or swim platform while engines are running.
- Slow down and look for swimmers or skiers when cruising in an area where there might be persons in the water.



SECTION 1 • SAFETY

B. SKIING

WARNING

Skiers must wear an approved PFD.

It is advised that you become familiar with water skiing safety and hand signals as you will most likely, on occasion, find yourself in the vicinity of or engaging in water skiing activity.

- Anyone who water skis must know how to swim.
- Never drive the boat directly behind a water skier. At 22 knots (25 m.p.h.), it takes only 5 seconds to overtake a fallen skier who was 60 meters (200 feet) in front.
- Keep a downed skier in sight and on the operator's side of the boat when approaching the skier. Never back up to anyone in the water.
- Learn the signals to communicate with a skier. The skier is to control the boat through hand signals (Fig. 1.10.1).

Turn – Arm raised, circle with index finger extended.

Skier in Water – Extend one ski vertically out of water.

Back to Dock – Pat top of head.

Cut Motor – Draw finger across throat.

Slow Down – Thumb pointed down or palm down, move hand up and down.

Faster – Thumb pointed up or palm up, move hand up and down.

OK – Raise arm and form a circle with thumb and index finger.

Stop – Raise arm with palm vertical and facing forward.

Turn Right – Extend arm out from body to the right.

Turn Left – Extend arm out from body to the left.

OK After a Fall – Clasp hands together overhead.

- If the skier suddenly releases the tow rope, it can backlash into cockpit. Spotters who are watching the skier must be aware of this fact and be prepared to deflect the rope by hand to avoid injury.

C. DIVING

- Recognize and respect diving flags (Fig. 1.10.2). Keep at least 30 meters (100 feet) away.

Sport Divers Flag – Red flag with diagonal white stripe marks a diver in the water.

Code Alpha Flag – Blue and white pennant designates boat being used in dive operations.

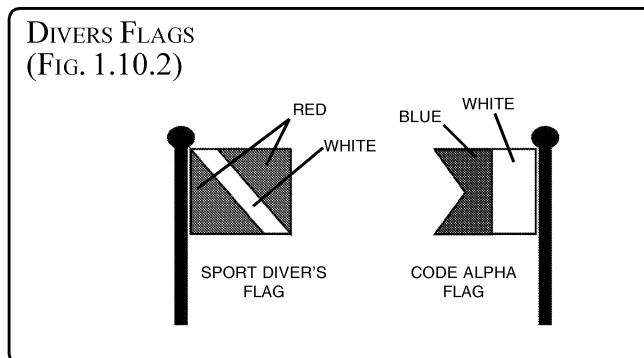
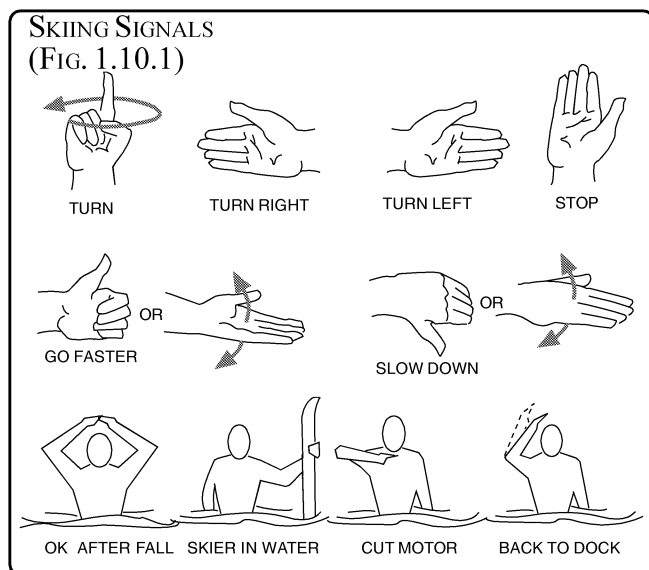

SECTION 1 • SAFETY

IN GENERAL

When engaged in water sports, be safe and courteous to others sharing the water:

- Be considerate to fishermen.
- Do not water ski in congested areas.
- Keep the boat and skier away from navigation markers.
- Stay well clear of other boats and skiers.

15. EMERGENCY SITUATIONS

Prevention is the safest approach. We hope that you are never involved in an emergency situation.

If you are involved in an emergency situation, it is imperative that you know how to react, in order to protect the lives in your care.

ASSISTING OTHER BOATERS

All boaters have a legal obligation to help other boaters who are in distress, as long as rendering assistance does not endanger you, your passengers or your boat.

A. MEDICAL EMERGENCY

You may be far from professional medical help when you are boating. At least two people on board your boat should be CPR certified, and should have taken a first aid course. Equip your boat with a first aid kit.

B. WATER RESCUE

A person who has fallen overboard will die from hypothermia in water temperatures below 70°F if not rescued quickly. Water rescue consists of three steps: returning to the victim, making contact with the victim, and getting the victim back on board.

RETURNING TO THE VICTIM

- Immediately make everyone aware of the incident and keep the victim in sight.

- Slow the boat and keep pointing toward the person overboard. At night, direct the best available light source at the person.
- Throw a life preserver, even if the person is wearing a PFD. It will serve as another marker.

MAKING CONTACT

- Stop or slow the boat and circle toward the victim.
- Try to approach heading into the wind or into the waves.
- Keep the victim constantly in sight.
- When almost alongside, stop the engine in gear to prevent propeller “windmilling.”

GETTING BACK ABOARD

- Try to reach the victim with a pole, or by throwing a life preserver. Do not swim to rescue the victim, except as a last resort.
- Assist the person in boarding the boat. The person should normally be brought in over the stern.
- If the person is injured or cannot get into the boat, a rescuer should put on a PFD with a safety line attached to the boat and enter the water to assist the victim.
- Handle the victim with care. Spinal injuries may have occurred.

C. FIRE

Fire is a serious boating hazard. Boats will burn quickly. Do not remain on board and fight a fire for more than a few minutes. If the fire cannot be extinguished within a few minutes, abandon the boat.

Have fire extinguishers handy. A small fire can be extinguished quickly with the right size and type of fire extinguisher.

- Extinguish smoking materials, shut off blowers, stoves, engines and generators.



SECTION 1 • SAFETY

- Throw burning materials overboard, if possible.
- If the fire is accessible, empty the contents of fire extinguishers at the base of the fire.
- If the fire is in the engine compartment and you have an automatic extinguisher for the engine, wait 15 minutes before opening the compartment. Have a portable extinguisher ready in case the fire flares up.
- Signal for help.
- Grab distress signals and survival gear. Put on PFDs. Prepare to abandon ship.
- Stay with the boat.
- Signal for help.
- If a leak patch is attempted, it should be done from the outside.
- In the event of a collision, you are required to file an accident report. Contact a state enforcement agency or the nearest Coast Guard office. If you are boating outside of U.S. waters, consult the nation you are visiting for accident reporting requirements.

D. FLOODING, SWAMPING AND CAPSIZING

In the event of flooding, swamping or capsizing:

- Try to shut off engines, generators and blowers, before leaving the boat.
- Have everyone put on Personal Flotation Devices (PFD's).
- Account for all who were on board.
- If the boat is floating stay with the boat. Hang on, or climb on the boat and signal for help.
- Only as a last resort should you attempt to swim to shore - it is further away than it looks and you can tire and drown.

E. COLLISIONS AND LEAKING

In the event of collision and leaking:

- Slow down or stop to reduce water intake, unless maintaining speed will keep the hole above water.
- Switch on bilge pumps.
- If equipped, operate the manual bilge pump if the powered bilge pumps can't handle the water flow.
- Account for everyone on board and check for injuries.
- Have everyone put on PFDs.

F. GROUNDING

In the event of running aground:

- Check for leaks. If water is coming in, stop the intake of water before attempting to get the boat free.
- Inspect for damage to the hull, propulsion and steering systems.
- Determine if the tide, wind and current will drive the boat harder aground or will help to free it.
- Determine the water depth all around the boat, and the type of bottom (sand, mud, rocks, etc.). If it can be done without exposing persons to risk of injury, the boat should be moved away from hard obstructions and toward open water with soft ground.
- Do not attempt to have your boat towed by other than a trained and competent service, such as the Coast Guard or a salvage company. Recreational craft are not designed to tow other recreational craft.

G. PROPULSION, CONTROL OR STEERING

FAILURE:

If the drive train fails, or controls or steering do not respond properly at all:

- Shut off engine.
- Put out the anchor to prevent drifting.



SECTION 1 • SAFETY

- Determine whether or not you can repair the problem yourself. See the proper manuals for assistance in troubleshooting the engine, steering and engine controls.
- If you are not sure you can fix the problem, or if conditions are adverse, signal for help.

16. SAFETY HOTLINES

The safety information in the preceding pages gives only the general areas of concern for boating safety. It is not intended to be, nor can it be, exhaustive. You must take a boating safety course, and get hands-on instruction in the proper and safe operation of your boat from experienced persons before cruising.

The U.S Coast Guard offers many pamphlets on safety and other information not covered in this book. Contact your local Coast Guard unit or call the toll-free safety hotlines below for information.

- U.S. Coast Guard 1-800-368-5647
- Canadian Coast Guard 1-800-267-6687

In other countries, ask your marine dealer for information on how to contact the national boating law enforcement agency.

17. INTERNATIONAL REQUIREMENTS

This vessel and its systems have been constructed in accordance with standards and specifications in effect at the time of manufacture as published by the various regulatory authorities listed below.

1. Ministere De La Mer - France
2. Registro Italiano Navale - Italy
3. Det Norske Veritas - Norway
4. Securite des Nauires - Canada
5. J.C.I. (Japan Craft Inspection) - Japan
6. N.K.K. (Nippon Kaiji Kyokai) - Japan
7. B.S.I. (British Standards Institute) - England
8. Ministerio Obras Publicas Y Transporters - Spain

9. EC Recreational Craft Directive - European Community.

Further information concerning these requirements may be obtained from Sea Ray® Customer Service: 1-800-SRBOATS.

18. NAUTICAL TERMS

Abeam – object 90 degrees to center line on either side of boat.

Abaft – a point on a boat that is aft of another.

Aft – toward the rear or stern of the boat.

Beam – the width of a boat.

Bow – the fore part of a boat..

Bow Eye – Bolt with looped head mounted on extreme forward part of bow.

Bulkhead – vertical partition in a boat.

Chine – meeting juncture of side and bottom of boat.

Chock – deck fitting, used as guides for mooring or anchor lines. Also, a wedge to stop wheels from rolling.

Cleat – deck fitting with arms or horns on which lines may be made fast.

Cockpit – an open space from which a boat is operated.

Deck – upper structure which covers the hull between gunwales.

Draft – depth of water required to float boat and its propulsion system.

Fathom – six feet.

Fenders – rope or plastic pieces hung over the side to protect the hull from chafing.

Freeboard – height of exposed hull from water line to deck.

Ground tackle – general term referring to anchors, anchor lines, etc.

Gunwale (pronounced gun'l) – meeting juncture of hull and deck.

Hatch – an opening in deck to provide access below.

Head – toilet or toilet area in a boat.

Headroom – vertical distance between the deck and cabin or canopy top.



SECTION 1 • SAFETY

Helm – steering console.

Hull – the basic part of a boat that provides buoyancy to float the weight of the craft and its load.

Keel – the major longitudinal member of a hull; the lowest external portion of a boat.

Knot – unit of speed in nautical miles per hour.

Lee – the side that is sheltered from the wind.

PFD – Personal Flotation Device; life preserver.

Port – term designating left side of the boat.

Rudder – Movable fixture at the stern used for steering.

Scupper – hole permitting water to drain overboard from deck or cockpit.

Sheer – curve or sweep of the deck as viewed from the side.

Snub – to check or tighten a line suddenly.

Starboard – term designating right side of the boat

Stern – the aft end of a boat.

Stern drive – outboard unit of an inboard/outboard (I/O) engine installation.

Stringer – longitudinal members fastened inside the hull for additional structural strength.

Transom – transverse part of stern.

Wake – disturbed water that a boat leaves behind as a result of forward motion.



Windward – toward the direction from which the wind is blowing.



SECTION 1 • SAFETY

19. KEY TO SYMBOLS ON CONTROL & PRINTS

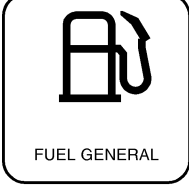
These symbols may be found on your controls and gauges and/or used in this owner's manual. This page is to help you understand what the symbols mean.

 PROPULSION SYSTEM TRIM	 PROPULSION SYSTEM TRIM BOW UP	 PROPULSION SYSTEM TRIM BOW DOWN	 TRIM TAB TRIMMING OPERATION	 TRIM TAB TRIMMING OPERATION	 TRIM TAB TRIMMING OPERATION
 LIFT POINT / SLING LOCATION	 ENGINE START	 ENGINE STOP	 FUEL LEVEL	 FUEL FILTER	 ENGINE COOLANT
 ENGINE WATER JACKET TEMPERATURE	 ENGINE OIL PRESSURE	 WARNING ELECTRICAL HAZARD	 FIRE RISK	 NO OPEN FLAME NO SMOKING	 ROTARY CONTROL (WIDTH OF SYMBOL INDICATES INCREASE)
 FRESH WATER	 WASTE WATER/SEWAGE	 FRESH WATER SYSTEM	 LEADED FUEL	 UNLEADED FUEL	 OIL
 FUEL GENERAL	 DIESEL FUEL	 LIFT POINT	 PROPELLER	 ENGINE ROTATIONAL SPEED	 BILGE PUMP
 BILGE BLOWER	 INTERIOR LIGHT	 COCKPIT LIGHTS	 RUNNING LIGHTS UNDER POWER	 ANCHOR LIGHT	 WINDSHIELD WIPER
 WINDSHIELD WASHER	 WINDSHIELD WIPER AND WASHER	 COMPASS	 ANCHOR	 HORN	 BATTERY



SECTION 1 • SAFETY

THIS PAGE LEFT INTENTIONALLY BLANK



20. 185 Sport Warning Label Locations

WARNING LABEL LOCATIONS
(Fig. 1.17.1)

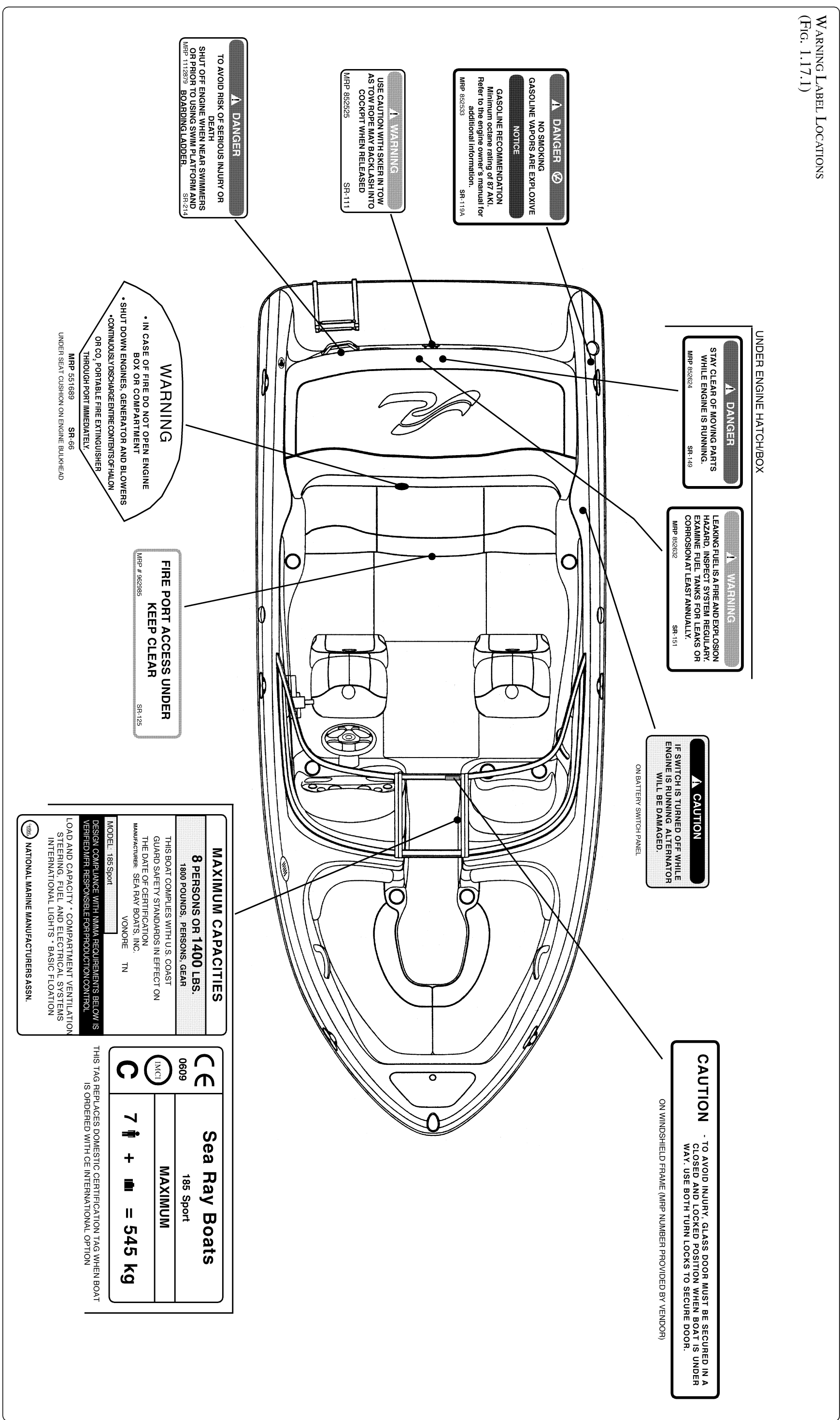

UNDER ENGINE HATCH/BOX

⚠ DANGER
STAY CLEAR OF MOVING PARTS WHILE ENGINE IS RUNNING.
MRP 852624 SR-149

⚠ WARNING
LEAKING FUEL IS A FIRE AND EXPLOSION HAZARD. INSPECT SYSTEM REGULARLY. EXAMINE FUEL TANKS FOR LEAKS OR CORROSION AT LEAST ANNUALLY.
MRP 852632 SR-151

⚠ CAUTION
IF SWITCH IS TURNED OFF WHILE ENGINE IS RUNNING, ALTERNATOR WILL BE DAMAGED.
ON BATTERY SWITCH PANEL

CAUTION
- TO AVOID INJURY, GLASS DOOR MUST BE SECURED IN A CLOSED AND LOCKED POSITION WHEN BOAT IS UNDER WAY. USE BOTH TURN LOCKS TO SECURE DOOR.
ON WINDSHIELD FRAME (MRP NUMBER PROVIDED BY VENDOR)

⚠ DANGER
NO SMOKING
GASOLINE VAPORS ARE EXPLOSIVE
NOTICE
GASOLINE RECOMMENDATION
Minimum octane rating of 87 AKI.
Refer to the engine owner's manual for additional information.
MRP 852533 SR-119A

⚠ WARNING
USE CAUTION WITH SKIER IN TOW AS TOW ROPE MAY BACKLASH INTO COCKPIT WHEN RELEASED
MRP 852525 SR-111

⚠ DANGER
TO AVOID RISK OF SERIOUS INJURY OR DEATH
SHUT OFF ENGINE WHEN NEAR SWIMMERS OR PRIOR TO USING SWIM PLATFORM AND BOARDING LADDER.
MRP 1112879 SR-214

WARNING
• IN CASE OF FIRE DO NOT OPEN ENGINE BOX OR COMPARTMENT
• SHUT DOWN ENGINES, GENERATOR AND BLOWERS
• CONTINUOUSLY DISCHARGE ENTIRE CONTENTS OF HALON OR CO₂ PORTABLE FIRE EXTINGUISHER THROUGH PORT IMMEDIATELY.
MRP 551689 SR-36
UNDER SEAT CUSHION ON ENGINE BULKHEAD

**FIRE PORT ACCESS UNDER
KEEP CLEAR**
MRP # 962985 SR-125

MAXIMUM CAPACITIES	
8 PERSONS OR 1400 LBS. 1800 POUNDS, PERSONS, GEAR	
THIS BOAT COMPLIES WITH U.S. COAST GUARD SAFETY STANDARDS IN EFFECT ON THE DATE OF CERTIFICATION. MANUFACTURER: SEA RAY BOATS, INC. VONORE TN	
MODEL: 185 Sport	
DESIGN COMPLIANCE WITH NMMA REQUIREMENTS BELOW IS VERIFIED/MFR RESPONSIBLE FOR PRODUCTION CONTROL.	
LOAD AND CAPACITY • COMPARTMENT VENTILATION STEERING, FUEL AND ELECTRICAL SYSTEMS INTERNATIONAL LIGHTS • BASIC FLOATON	
NATIONAL MARINE MANUFACTURERS ASSN.	

 0609 	Sea Ray Boats 185 Sport MAXIMUM
	7 ↑ + ■ = 545 kg

THIS TAG REPLACES DOMESTIC CERTIFICATION TAG WHEN BOAT IS ORDERED WITH CE INTERNATIONAL OPTION



21. 185 Sport Dash Warning Label Locations

WARNING LABEL LOCATIONS
(FIG. 1.18.1)

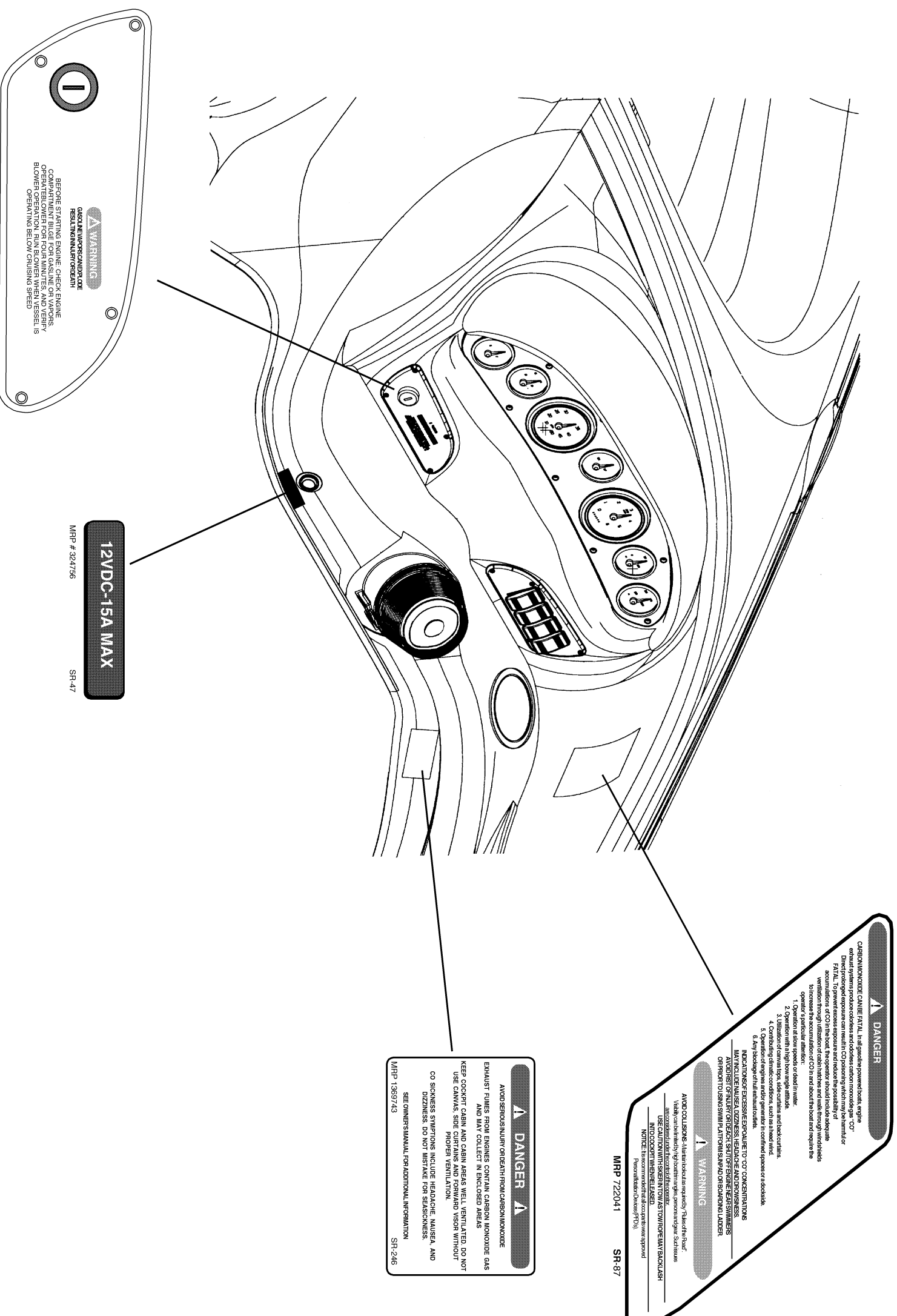

SECTION 2 • GENERAL BOAT ARRANGEMENT

1. DOCKING/LIFTING/TRAILERING

! CAUTION

Do Not use cleats for lifting.

BOW AND STERN CLEATS: (See Figure 2.1.1)
Cleats must not be used for lifting the boat, they are intended for docking or mooring use only.

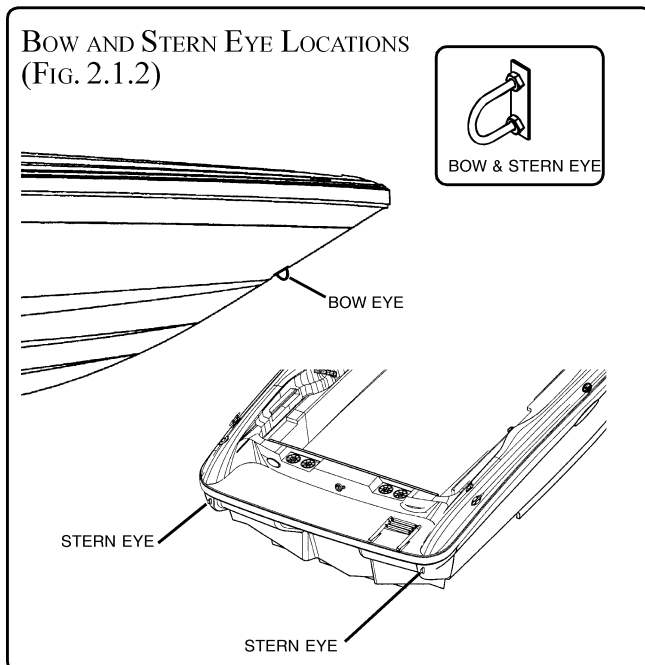
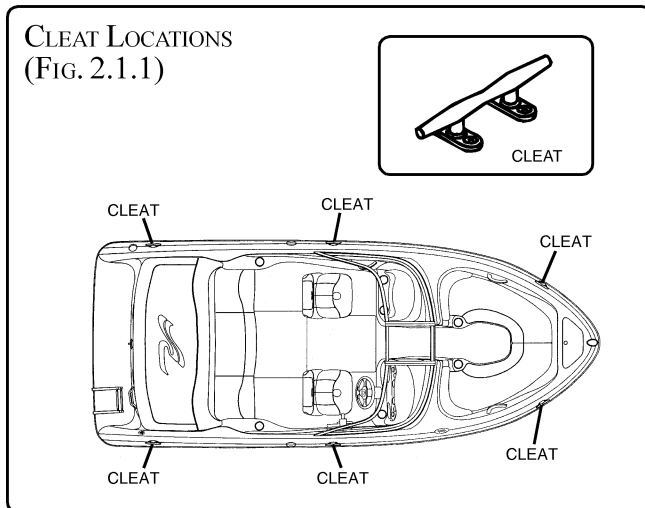

BOW AND STERN EYES: (Figure 2.1.2). The bow eye must be used to haul the boat onto a trailer. The stern eyes must be used as tie down points for

trailing the boat. The bow and stern eyes may be used for short term lifting of the boat such as for service. Long term lifting with the bow and stern eyes may cause stress on the fiberglass and gel coat.

For long term storage, use flat, wide belt-type slings and spreaders long enough to keep pressure from gunwales. Do not place slings where they may lift on underwater fittings.

2. PASSENGER LOCATIONS

! WARNING

Boat motion can be erratic.

You can fall overboard or be injured by hitting something in or on the boat.

All persons must be in cockpit area or cabin and be prepared for sudden boat movement.

Use front or bow deck area only during anchoring, mooring or emergencies.

! WARNING

Wet decks are slippery.

You can be seriously injured if you slip and fall.

Wear slip resistant footwear secured to your feet and hold on to rails or boat structure.

1. When the boat is moving, all passengers must be in the cockpit area or in the cabin and must be on seating provided or, if standing, holding on firmly (See Figure 2.2.1).

While the person at the wheel must alert passengers before any sudden or erratic boat movement, such as crossing wakes, rapid turns, sudden acceleration or deceleration, etc., an emergency action may be necessary before passengers can be warned. All passengers must be prepared for rapid boat movement and be able to hold on to prevent loss of balance.

2. When persons are on the working deck area, for anchoring, mooring or in emergencies, they



SECTION 2 • GENERAL BOAT ARRANGEMENT

must be holding on and be positioned so as to prevent falling. In bad weather and/or rough water, if it is essential to be on deck, persons should be closely tied to cleats, railing stanchions or other securely fastened boat hardware.

- Engines must be turned off if the boat is near swimmers or persons are on the swim platform or the swim ladder.

3. PROPULSION SYSTEM

Your boat is equipped with a stern drive propulsion system also known as an inboard-outboard engine (Figure 2.3.3). This type of propulsion system has the engine inside the boat secured to the hull's stringers at the rear end of the hull. The stern drive unit, also called the lower unit because it hangs below the hull, is part of the propulsion system that attaches to the outside of the hull or transom. The stern drive unit pivots to steer the boat.

For engine operating instructions, see page 3.4

PASSENGER LOCATIONS
(FIG. 2.2.1)

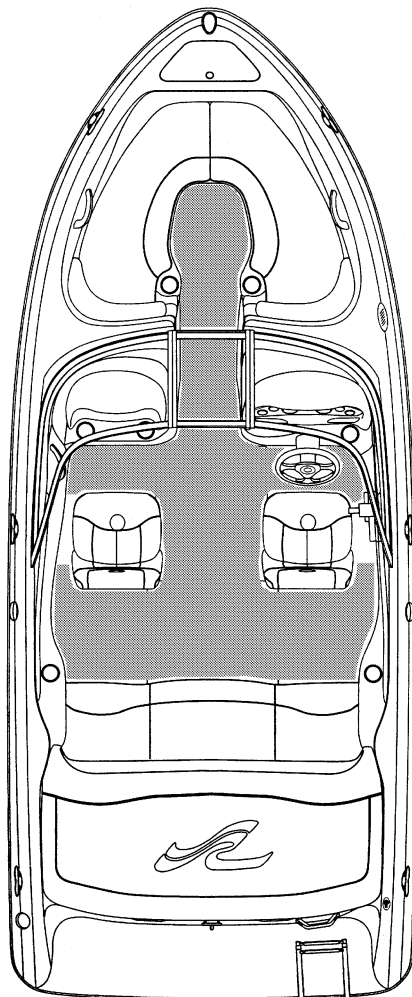

ACCOMMODATION DECK
(DECK AREA INTENDED FOR
OCCUPATION DURING NORMAL
OPERATION)

! WARNING

Wet decks are slippery.

You can be seriously injured if you slip and fall.

Wear slip resistant footwear secured to your feet and hold on to rails or boat structure.

! DANGER

Rotating propellers can injure or kill you.

Shut off engine when persons are in water, near boat, on swim platform or ladder.



SECTION 2 • GENERAL BOAT ARRANGEMENT

4. BASIC BOAT DIMENSIONS AND CLEARANCES

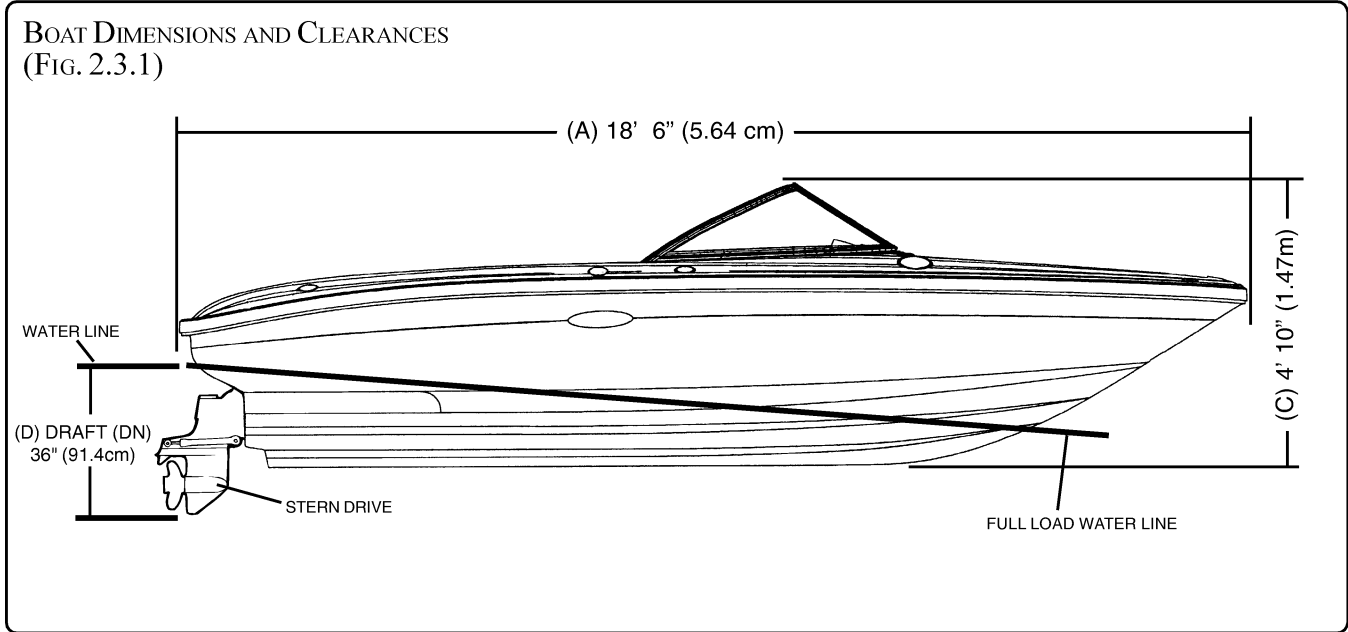

185 SPORT SPECIFICATIONS

(A) Overall Length	18ft. 6in.	5.64m
(B) Beam (Width)	7ft. 6in.	2.29m
(C) Draft (Stern Drive Down)	36"*	91.4cm*
*MINIMUM WATER DEPTH TO PREVENT RUNNING AGROUND (Stern Drive Up)		
	18"	45.7cm
Dry Weight	2,650 lbs.	1,193 kg.
Fuel Capacity	26 gal.	98.4 liters
Useable Fuel	24.7 gal.	93.5 liters
Dead Rise	19°	

HEIGHT DIMENSIONS

(D) Height Overall	4ft. 10in.	1.47m
--------------------------	------------	-------

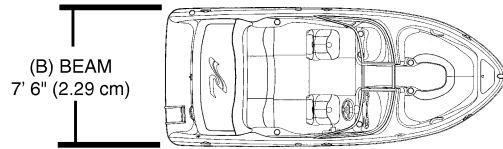
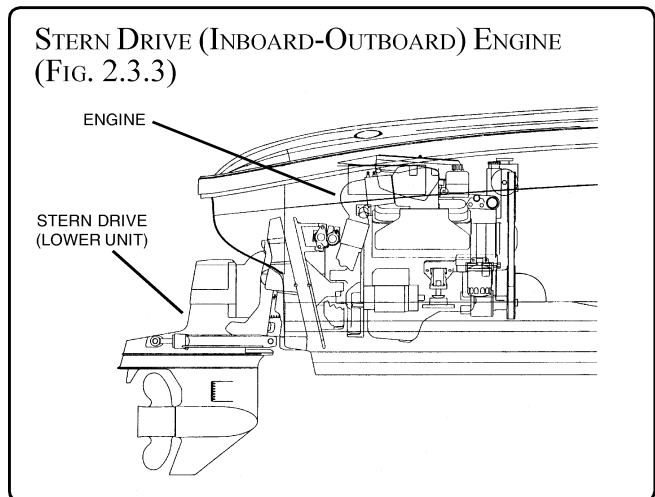

FIG. 2.3.2

5. PROPELLERS

Your Sea Ray® has been equipped with propellers which our tests have shown to be the best suited for general use under normal conditions and load.

Under no circumstances use a propeller which allows the engine to operate at higher than maximum RPM for your engine.



SECTION 2 • GENERAL BOAT ARRANGEMENT

6. GENERAL DECK LAYOUT

GENERAL LAYOUT (STANDARD)
(FIG. 2.4.1)

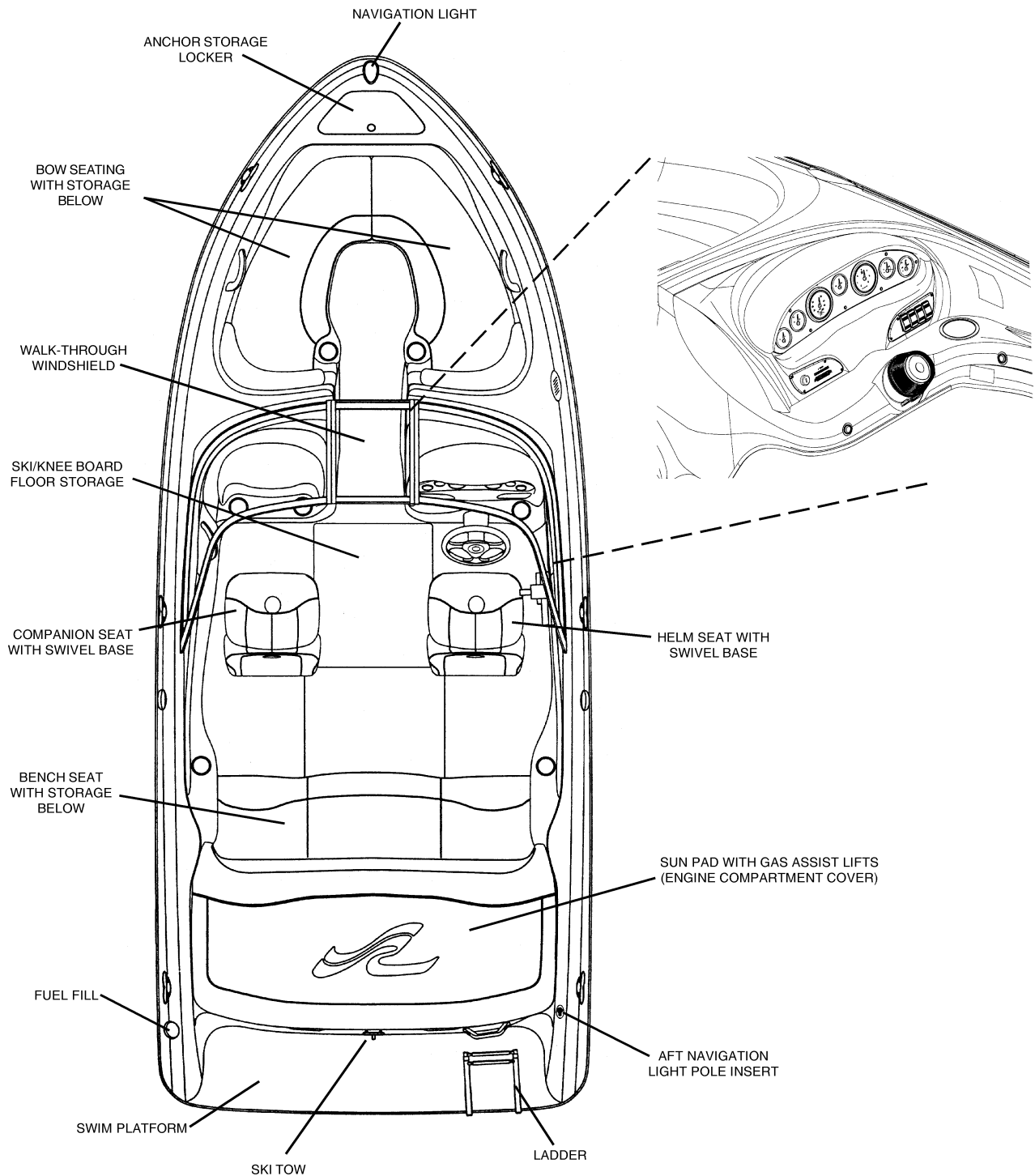

SECTION 2 • GENERAL BOAT ARRANGEMENT

GENERAL DECK LAYOUT (CONTINUED)

GENERAL LAYOUT (OPTION)
(FIG. 2.5.1)

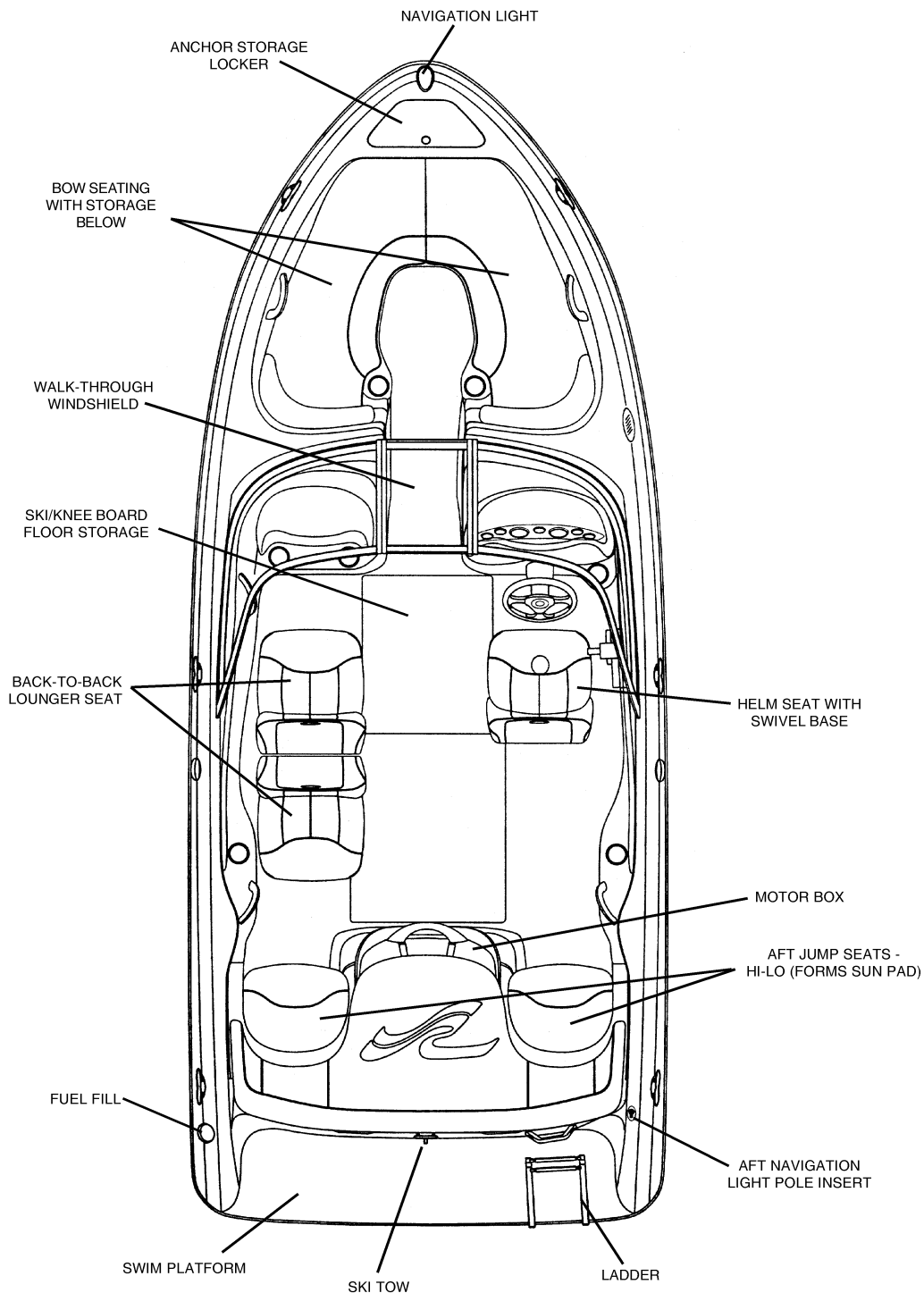

SECTION 2 • GENERAL BOAT ARRANGEMENT

GENERAL DECK LAYOUT (CONTINUED)

GENERAL LAYOUT (OPTION)
(FIG. 2.6.1)

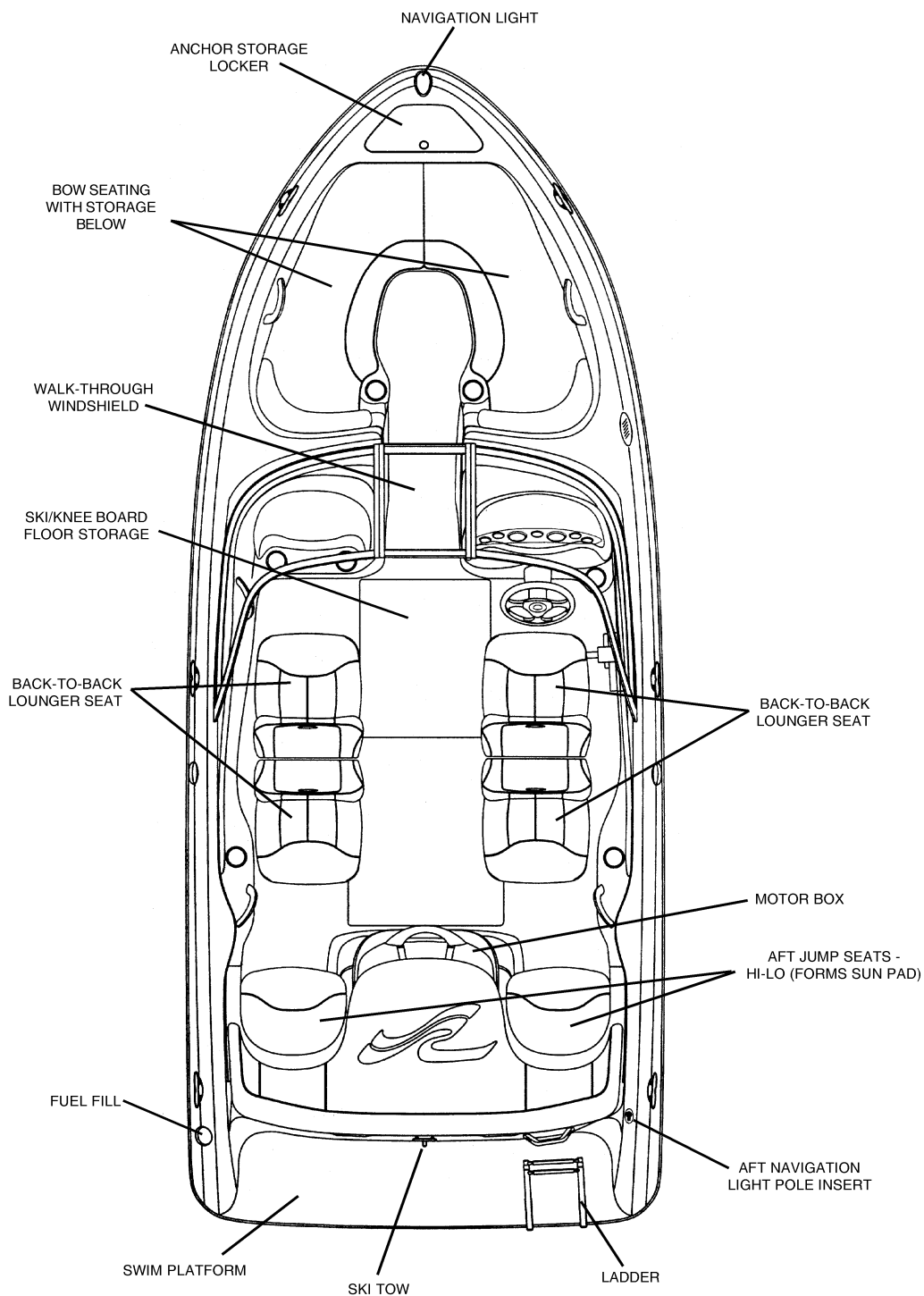

SECTION 2 • GENERAL BOAT ARRANGEMENT

7. HELM GAUGE AND SWITCH LAYOUT

HELM GAUGES AND SWITCHES
(FIG. 2.7.1)

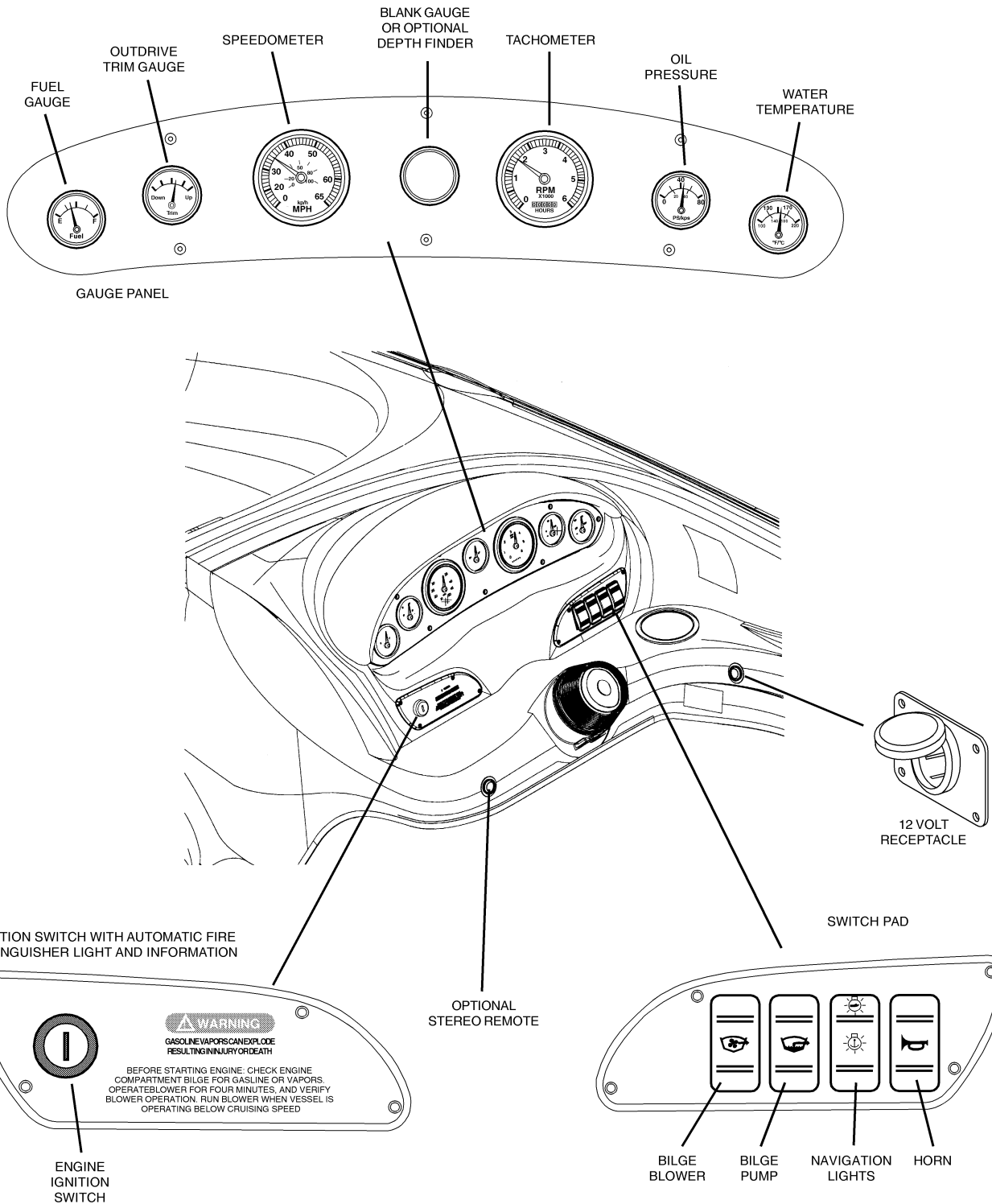

SECTION 2 • GENERAL BOAT ARRANGEMENT

8. FUNCTION AND LOCATION OF THROUGH-HULL CUTOUTS

STARBOARD THROUGH-HULL CUTOUTS
(FIG. 2.8.1)

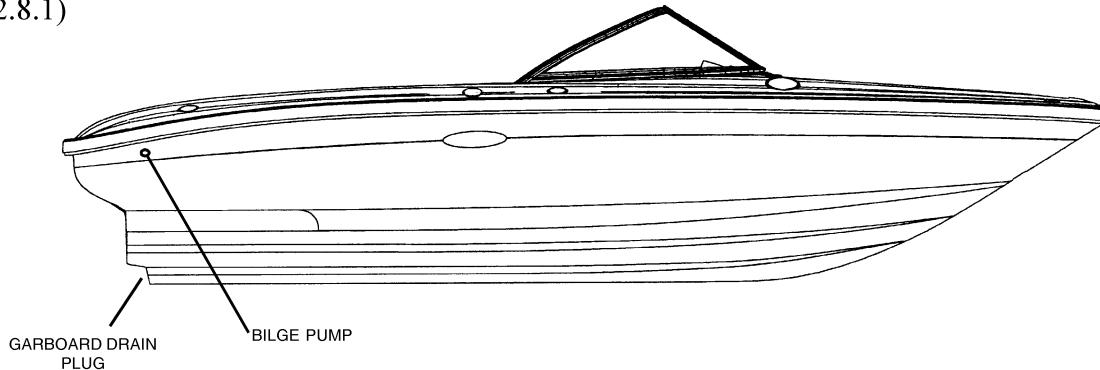

9. DESCRIPTION OF MAJOR CONTROLS

A. GEAR SHIFT AND THROTTLE CONTROL

The shift/throttle control unit for the engine activates by the the shifting mechanism and the throttle (Figure 2.8.2). The control must be in neutral position to start your engine. Moving the lever forward first engages the forward gear. Further forward movement increases engine speed and propeller RPM, moving the boat faster. To shift to reverse, bring th control lever back to the neutral position, then move it further back to engage the reverse gear. Furhter rearward movement of the lever increases engine speed and propeller RPM, moving the boat faster in reverse.

Shift/throttle controls are equipped with a “throttle only” mechanism which allows the shift mechanism to be disengaged from the throttle. This allows the throttle to be advanced without shifting the transmission when starting. It may be necessary to use the “throttle only” button in order to pump fuel into the engine for ease in starting.

The “throttle Only” mechanism (Figure 2.8.2) may differ from one style gear/throttle unit to another. Refer to your Gear Shift & Throttle Manual for proper operation of this feature.

The throttle control adjusts the RPM of the engine and thus, the rotational speed of the propeller. Regulating the RPM of the engine controls the speed of the boat.

Forward motion creates forward moving water called a “following” wake. If the boat is moving forward and the shift/throttle is moved quickly from forward to reverse, the boat will stop rapidly and

GEAR SHIFT AND THROTTLE CONTROL
(FIG. 2.8.2)

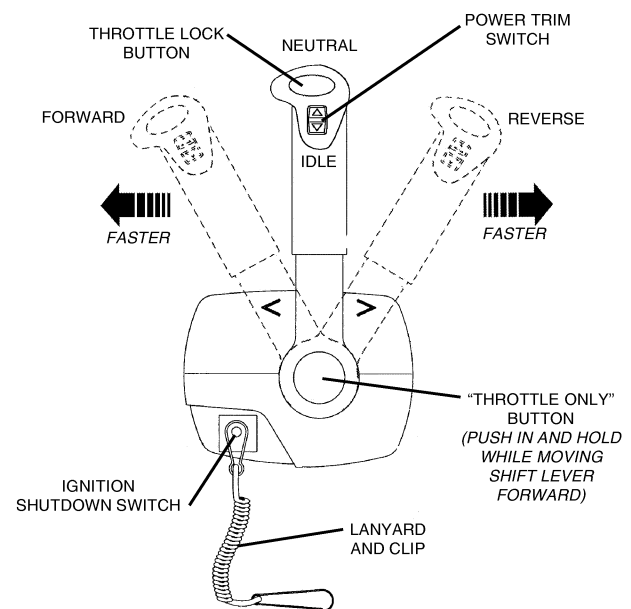

SECTION 2 • GENERAL BOAT ARRANGEMENT

then move backward. The following wake continues to move forward and can rise above the transom and flood the boat.

CAUTION

Cockpit can fill with water if boat is moving forward, when it is put into reverse.

Before shifting into reverse, shift to neutral, wait for boat to stop moving forward, then shift into reverse.

Do not shift into reverse too quickly. Wait for the following wake to dissipate.

B. POWER TRIM UNIT AND GAUGE

The power Trim allows the operator to raise and lower the stern drive unit while underway to provide the ideal boat angle (in relation to water surface) for a given load and water condition.

Trimming UP rotates the stern drive and propeller away from the transom. Trimming DOWN rotates the stern drive and propeller closer to the transom.

When the stern drive is trimmed DOWN, the bow of the boat is being forced down. If the trim is in the full DOWN position when accelerating from idle to plane, the boat will plane faster with less bow rise. Once on plane, the stern drive unit can be trimmed UP slightly. This will raise the bow of the boat slightly and increase speed. You will need to try small differences in the stern drive position to determine the trim position you prefer under various conditions.

If you raise the stern drive up too far while you are on plane, you could cause a loss of speed and power due to a condition called propeller “ventilation.” If this happens, there will be a sudden increase in engine RPM and loss of speed. Do not let this condition exist. Immediately reduce your engine RPM and trim the outdrive DOWN slightly until engine slows down and you regain forward speed.

The trim gauge indicates the position of the stern drive relative to the transom.

REFER TO YOUR ENGINE OPERATOR'S MANUAL FOR PROPER TRIM GAUGE SETTING.

EFFECTS OF POWER TRIM
(FIG. 2.9.1)

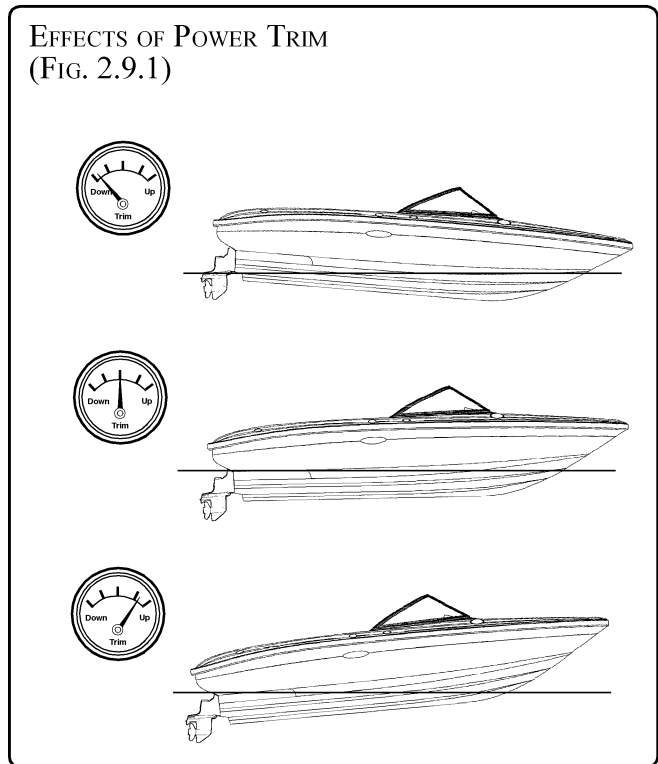

C. TRAILER SWITCH

The trailer switch (power trim switch) (Figure 2.8.2) is not to be confused with the power trim function. The trailer switch is to be used only when the engine is OFF.

The trailer switch allows the drive unit to be raised for trailering, beaching and launching. To operate, press and hold the trailer switch until the drive unit reaches the end of upward travel. The mechanism that raises the lower unit will stop operating at the end of the upward travel. To bring the drive unit down into boating position, push the power trim switch down.

SECTION 2 • GENERAL BOAT ARRANGEMENT

D. IGNITION SHUTDOWN SWITCH (STANDARD ON SIDE MOUNT CONTROLS)

The purpose of the ignition shutdown switch (Figure 2.10.1) is to shut down the engine, if the operator unintentionally leaves the helm. Situations in which this could occur are rough water, bad weather and other adverse boating conditions. In these situations, the safety of the boat and its passengers is enhanced by using the ignition shutdown switch, since the boat will stop when the operator can no longer control the boat.

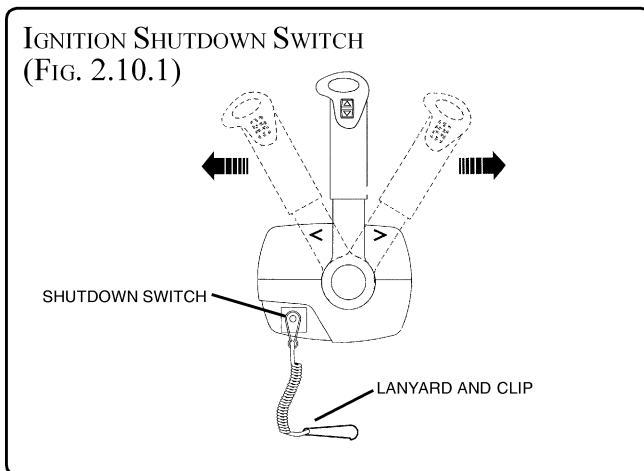

However, unintentional engine shutdown may result in unintentional harm. For example, a passenger may lose balance and fall, or control could be lost during docking. No specific guidelines can be given for switch use. The ultimate decision of when to use an ignition shutdown switch, rests with the operator or owner.

When the switch is used, the operator must securely clip the lanyard to their belt or clothing so that if the operator falls overboard or into the boat, the switch is activated and the engine shuts down.

To reset the ignition shutdown switch after it has been activated, simply reinstall the switch clip above the shutoff switch and flip the switch to the UP position.

E. ENGINE ALARM SYSTEM (ONLY ON CERTAIN ENGINES)

CAUTION

Always check oil pressure and water gauges while moving, even if your engine has an alarm.

Shut down engine immediately if gauges are not in normal ranges, or alarm sounds.

Do not restart engine until problems are corrected.

The engine Operator's Manual will tell you if your engine is equipped with an audible alarm and how to use it.

The alarm indicates a problem with engine water temperature, oil pressure and/or stern drive oil level.

10. IMPORTANT GAUGES

A. TACHOMETER AND HOUR METER

The tachometer (Figure 2.10.2) indicates the revolutions per minute (RPM) of the engine. (It does not indicate the speed of the boat.) Your Engine Operator's Manual indicates the maximum full throttle RPM at which your engine should operate. This must not be exceeded or serious engine damage will occur. The tachometer should also be used to determine the most comfortable and economical cruising RPM.

TACHOMETER WITH HOURMETER
(FIG. 2.10.2)

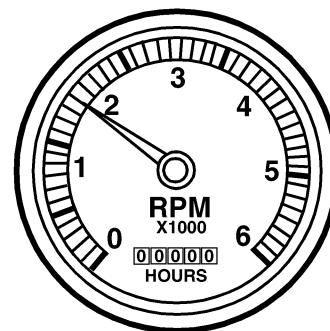

SECTION 2 • GENERAL BOAT ARRANGEMENT

The hourmeters measure cumulative hours of operating time. The hourmeter should be used to keep a careful log of engine maintenance as well as performance data and fuel consumption. Do not leave ignition key ON with the engines off, as this will increase the engine hours on the hourmeter.

B. OIL PRESSURE, WATER TEMPERATURE AND FUEL GAUGES

These gauges function on your boat the same way they do on your car or truck. You must continually check these gauges visually to make certain there are no engine system problems even if your boat engine has an alarm system.

11. NAVIGATION AND ANCHOR LIGHTS

Navigation lights (Figure 2.11.1) **MUST** be on while underway from sunset to sunrise or in conditions of reduced visibility. "Underway" means the boat is not docked or at anchor. Trolling or drifting with engine off is considered "underway" and navigation lights must be used.

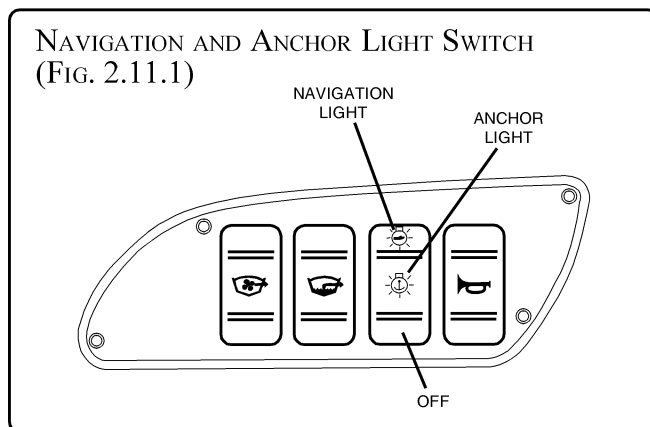

If you are anchored in open water, i.e. where other boats can approach yours, you must display your anchor light (Figure 2.11.2): a white light that can be seen from all possible directions, i.e. 360 degrees.

Read the "Federal Requirements and Safety Tips for Recreational Boats" provided in your kit.

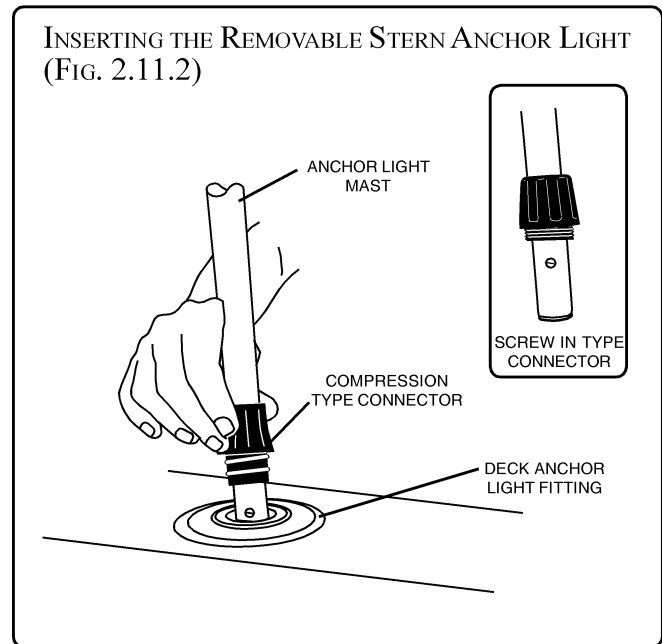

SECTION 2 • GENERAL BOAT ARRANGEMENT

THIS PAGE LEFT INTENTIONALLY BLANK



SECTION 3 • USING YOUR BOAT

1. PRE-LAUNCH, LAUNCH AND POST-LAUNCH CHECKLIST

Listed below are the critical items you must check and do each time you use your boat. It does not list all of the necessary maintenance and service items required to keep your boat running properly. These other items are found in Section 6.

BEFORE LAUNCH

- Drain plug installed
- Enough fuel for trip
- Float plan given to friend or relative
- Navigation charts for trip
- Weather forecast - safe

IN THE WATER, BEFORE BOARDING PASSENGERS OR STARTING ENGINE

- Stern drive down
- Equipment stored and balanced
- No gas smell in engine compartment
- Engine oil and steering fluid levels - OK
- Battery switch on
- Bilge pump working
- Bilge blower on
- Radio and navigation equipment functioning

PASSENGERS

- Wearing PFDs
- Seated properly
- Given safety instructions

STARTING ENGINE

- Make sure you have read and understand the dangers of Carbon Monoxide (CO) information in this manual.

- Bilge blower on for at least four (4) minutes. Feel to confirm airflow at hull vent on hull side. Inspect bilge area for visual and odor confirmation that there are no fuel leaks.
- Throttle-only position, handle pumped before starting, if necessary.
- Oil pressure, engine temperature, voltage - OK after starting and warm up.

UNDERWAY

- Gradual acceleration and deceleration and turning.
- Aware of surroundings at all times.
- Operate so as to prevent buildup of Carbon Monoxide (CO)
- Monitor weather
- Use navigational aids in water and on shore
- Keep passengers safe
- Check fuel consumption regularly
- Check all gauges frequently

END OF TRIP

- Equipment dry and stored.
- Electronic equipment and switches off.
- Battery switch off.
- Stern drive in trailering position.
- Notify person who had float plan.
- Boat covered properly for trailering, docking or mooring.
- Drain plug removed.
- Hull and propeller inspected for damage.

WARNING

An improper trailer can cause structural damage to the hull.

A damaged hull can be unsafe; it could cause the boat to sink.

Use a trailer that can properly support the boat's weight and shape. Get professional help in picking the right trailer for your boat.



SECTION 3 • USING YOUR BOAT

2. TRAILER LAUNCHING AND LOADING

Your trailer must be capable of carrying the boat's weight as well as supporting the boat near the keel, front (bow) and rear (stern) areas. Using a trailer not designed to support the boat properly, can cause structural damage to the hull. A damaged hull can be unsafe.

PROPER TOWING OF A BOAT AND TRAILER REQUIRES SPECIAL SKILLS. MAKE CERTAIN YOU PRACTICE HOW TO MANEUVER A BOAT AND TRAILER AND GET TRAINING BEFORE TOWING, LAUNCHING AND LOADING YOUR BOAT.

3. FUELING THE BOAT

The fuel fill cap is located on the deck on the left (port) side of the boat (Figure 3.2.1). Do not mistake the water tank fill and waste pump out caps for the gasoline fill cap.

! DANGER
NO SMOKING GASOLINE VAPORS ARE EXPLOSIVE
NOTICE
GASOLINE RECOMMENDATIONS
Minimum octane rating of 87 AKI.
Refer to the engine owner's manual for additional information

! DANGER
Gasoline vapors can explode from static electricity if fueling is not done properly.
Read and understand this section

Refer to your engine manual for the proper grade of gasoline.

BEFORE FUELING

- Fuel during daylight hours.

FUEL FILL LOCATION
(FIG. 3.2.1)

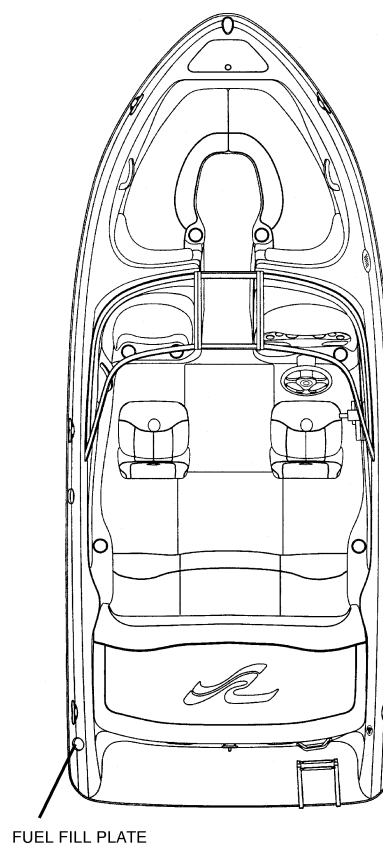
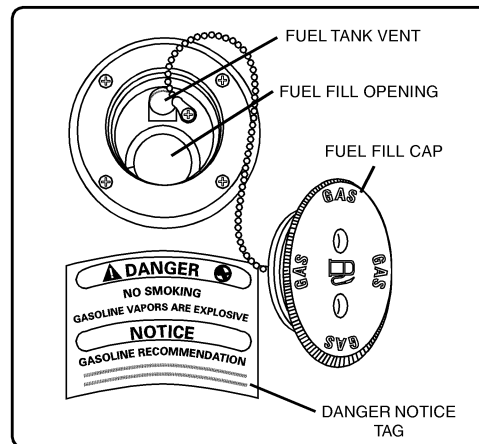

- If possible, position boat with the left (port) side against the fueling dock so that the fuel fill cap is easily accessible from the dock.



SECTION 3 • USING YOUR BOAT

- If the right (starboard) side of the boat is against the dock, remember that the fuel cap is on the other (port) side of the boat. Do not confuse the waste pump out cap with the fuel fill cap.
- Tie boat to the dock.
- Shut off engine, bilge blower and all other electrical equipment.
- Shut off gas burning appliances (gas stove, etc.).
- Close all hatches, doors and keep engine compartment closed to prevent gasoline fumes from entering the cabin or cockpit area.
- All passengers must leave the boat, as a precaution.
- There must be no smoking or any flames within 20 feet of the boat, before, during and for at least 5 minutes after fueling is completed.
- Open fuel fill cap and insert hose nozzle into the fuel fill opening. Fuel fill hose nozzle must contact the fuel fill opening **BEFORE** adding fuel to prevent discharge of static electricity.

FILLING THE TANK

- Check the fill plate label to ensure that fuel is placed **ONLY** in the fuel tank. The fuel fill plate is located on the port aft section of your boat (Figure 3.2.1).
- Keep nozzle in contact with fuel fill opening at all times during fueling.
- Listen as tank fills and stop adding gasoline before it spills from the vent. Gasoline must have room for expansion.

AFTER FILLING

- **DO NOT** wash spilled fuel overboard. Wipe up any spill with rags or paper towels and dispose of them properly on shore.

- Open engine compartment and check for gasoline fumes. Leave compartment open until no odor is apparent. Close compartment.
- If fumes in the engine compartment do not disappear, do not turn on blower or start engine. Get help from trained and experienced persons before using the boat.

4. BOARDING

- **DO NOT** overload the boat. Refer to Coast Guard capacity plate located near the helm (See Figure 1.17.1), and load to less than capacity in adverse conditions.
- Board one person at a time and give assistance as needed.
- Turn on blower for four minutes, then restart engine.
- Assist passengers back into the boat.
- Transfer gear and equipment by handing it from a person on the dock to a person on board. You can lose your balance and be injured if you attempt to board while carrying equipment or gear.
- Distribute the weight of equipment and passengers as evenly as possible to keep the boat balanced.
- Stow gear and equipment so that it is accessible, but everything is to be stored in places so as to prevent it from flying about if the boat encounters rough water or weather.

WARNING

Wet decks are slippery.

You can be seriously injured if you slip and fall.

Wear slip-resistant footwear secured to your feet and hold onto rails or boat structure.



SECTION 3 • USING YOUR BOAT

5. PERSONAL FLOTATION DEVICES (PFD's)

- Operator must instruct all passengers on location and use of PFD's (See *Section 1-Safety, page 4* for type and usage).
- Children less than sixteen (16) years of age and all non-swimmers, adults as well as children, must wear properly-sized PFDs at all times when aboard.
- ALL passengers should wear PFDs. By the time someone falls overboard, it can be too late for them to put on a PFD and fasten it properly. This is especially true in colder waters, below 70°F, where survival time, before hypothermia sets in, is measured in minutes.
- If there are passengers not wearing PFDs, the PFDs must be readily accessible. "Readily accessible" means out of the storage bag and unbuckled.
- All throwable flotation devices (cushions, rings, etc.) must be right at hand.

6. PASSENGER INSTRUCTION AND LOCATION

- Everyone on board must be told about the boat's behavior from starting to getting up on plane.
- Before the operator does any high-speed maneuvers or rapidly accelerates or decelerates the boat, passengers must be warned to sit and hold on and must heed the warning.
- The operator may have to make rapid changes in speed and/or direction to avoid a problem, with little or no time for alerting passengers. It is critical that all passengers be seated in the designated seating areas and holding on to prevent falling overboard or getting knocked about in the boat at all times when the boat is underway.

7. STARTING THE ENGINES

 **DANGER**

Gasoline vapors can explode

Before starting the engines, open engine compartment and check for gasoline smell.

- **If you smell gasoline, do not start engine; get everyone off the boat and get trained help to find and fix the problem.**

If there is no gasoline smell, perform checks specified by manual, then and only then, close engine compartment and run blower for at least 4 minutes before starting.

The engine operation and maintenance manual furnished with your boat describes pre-start and starting procedures. We urge you to thoroughly read and understand your engine manual.

Listed below are basic pre-start and starting reminders. These are not a substitute for the engine manufacturer's specific recommendations.

Open the engine compartment and check for the smell of gasoline.

- **IF YOU SMELL GASOLINE**, get everyone off the boat, do not operate any electrical switches or light any matches, lighters, etc. Get trained help to find and fix the problem, before starting the engine or operating any switches on the boat.
- If you **DO NOT** smell gasoline..
 1. Check all fluid levels and any other necessary checks as specified in *Section 8* and in the engine manual.
 2. Check that water level in bilge is minimal. Verify that the bilge pump is operating by turning the bilge pump switch to **MANUAL** and listening for the pump running and check to see that bilge water is being pumped overboard.



SECTION 3 • USING YOUR BOAT

3. Close engine compartment and turn on battery switch.

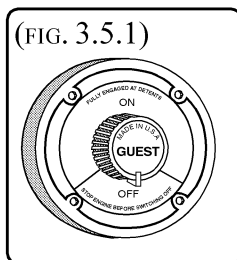

COLD ENGINE - press **THROTTLE ONLY** button and move shift/throttle lever forward to full open throttle, then return to about 1/4 throttle. In cold weather, it may be necessary to pump lever several times before engine will start.

WARM ENGINE - Press **THROTTLE ONLY** button and move shift/throttle lever about 1/4 open throttle position. Do not pump lever.

4. Check fuel level. Be sure you have enough fuel for your trip. Remember the "1/3 Rule": Use no more than 1/3 of your fuel for outbound trip; use 1/3 of the fuel for return trip; keep 1/3 for reserve in case of emergency.

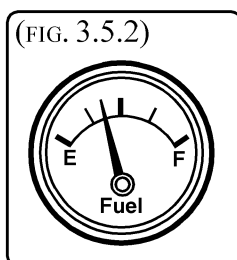

FLOODED ENGINE - press **THROTTLE ONLY** button and move shift/throttle lever to full open position. **DO NOT** pump lever. When the engine starts, move shift/throttle lever back rapidly to decrease engine speed to between 1000 and 1500 RPM.

5. Run bilge blowers for at least 4 minutes before attempting to start engine

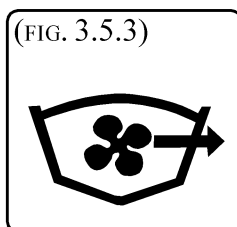

Unlike your automobile engine which is naturally ventilated even when it is not moving, your boat engine compartment (the bilge) does not have sufficient natural ventilation when the boat is not moving or moving slowly. That is why the engine compartment must have forced ventilation, using the bilge blower, to remove potentially explosive gasoline vapors, before the engine is started and when the boat is moving slowly.

Because it may be difficult to remember to turn on the bilge blower every time you slow down the boat, it is recommended that the bilge blower run all the time the engine is running.

6. Place drive unit in full **DOWN/IN** position.
7. Put throttle and shift control lever into neutral; then for a:

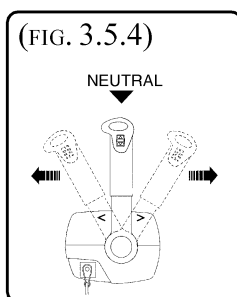

8. **TO START ENGINE:**

Turn ignition key clockwise, as in a car, and release when engine starts. Do not crank engine for more than a few seconds if it doesn't start. Engine may be very cold or flooded; see step 7.

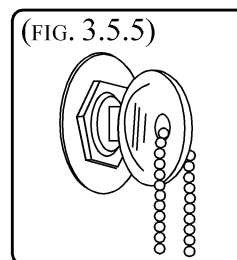

9. After engine starts, reduce speed to between 1000 and 1500 RPM and check oil pressure.

10. If oil pressure is correct, let engine warm up to normal temperature range as specified in the engine manual, before shifting into forward or reverse gear.

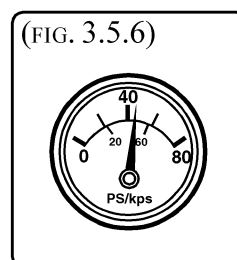

IF ENGINE TEMPERATURE GOES ABOVE NORMAL RANGE. SHUT DOWN THE ENGINE IMMEDIATELY. GET TRAINED HELP TO FIND AND FIX THE PROBLEM.

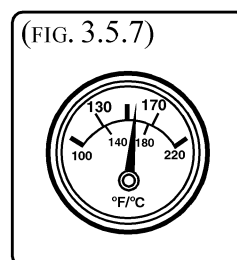

SECTION 3 • USING YOUR BOAT

IF OIL PRESSURE GOES ABOVE OR BELOW OPERATING RANGE, SHUT ENGINE DOWN IMMEDIATELY. GET TRAINED HELP TO FIND AND FIX THE PROBLEM.

2. Turn ignition key off. Do not use emergency stop switch to shut off engine.

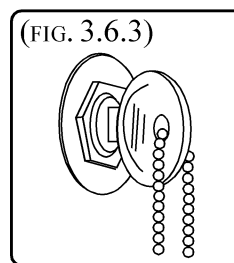

8. SHIFTING TO DRIVE THE BOAT

Bring shift/throttle lever back to neutral position. The THROTTLE ONLY button will pop out.

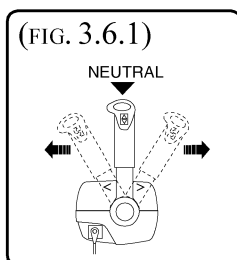

Then move shift/throttle lever rapidly, either forward or reverse, but not very far from the neutral position. The drive unit will engage and boat will start to move slowly in either forward or reverse. You can damage the transmission if you do not shift quickly from neutral into gear. Once clear of the dock, mooring, people and/or the no-wake zone and the boat has been shifted into forward gear, move shift/throttle lever forward to desired engine speed.

3. If you are leaving the boat for more than two hours, turn battery switch OFF.

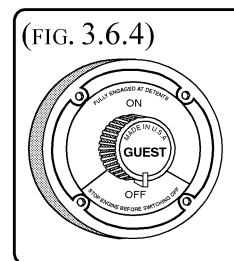

10. STEERING SYSTEM

The steering system is an enclosed push-pull cable that is hydraulically assisted (power steering) at the stern drive end (Figure 3.7.1 & 3.7.2). THE CABLE AND ITS CONNECTIONS TO THE STEERING WHEEL AND TO THE OUT DRIVE MUST BE INSPECTED AT LEAST TWICE A YEAR BY YOUR SEA RAY DEALER. See *Section 8* of this manual for inspection, service and maintenance recommendations.

CAUTION

Cockpit can fill with water if boat is moving forward, when it is put into reverse.

Before shifting into reverse, shift to neutral, wait for the boat to stop moving forward, then shift into reverse.

WARNING

Failure of the steering system will cause loss of control of your boat. Any change in steering such as looseness, tightness, binding, etc., must be checked immediately by your Sea Ray dealer.

9. STOPPING THE ENGINES

1. Move shift/throttle lever to NEUTRAL and let engine idle for about 5 minutes to allow engine to cool down.

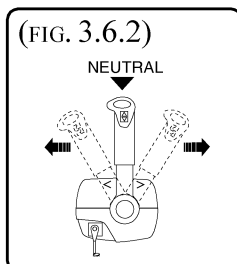

The power steering pump (Figure 3.7.1) fluid level MUST be checked every time prior to using the boat. Refer to the steering system information in your Owner's Packet.

SECTION 3 • USING YOUR BOAT

POWER STEERING SYSTEM
(FIG. 3.7.1)

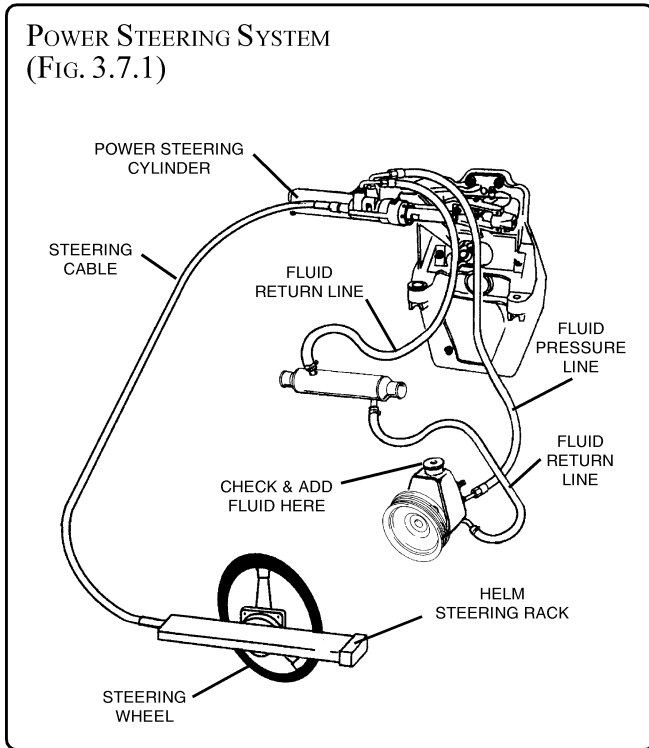

POWER STEERING CABLE ROUTING
(FIG. 3.7.2)

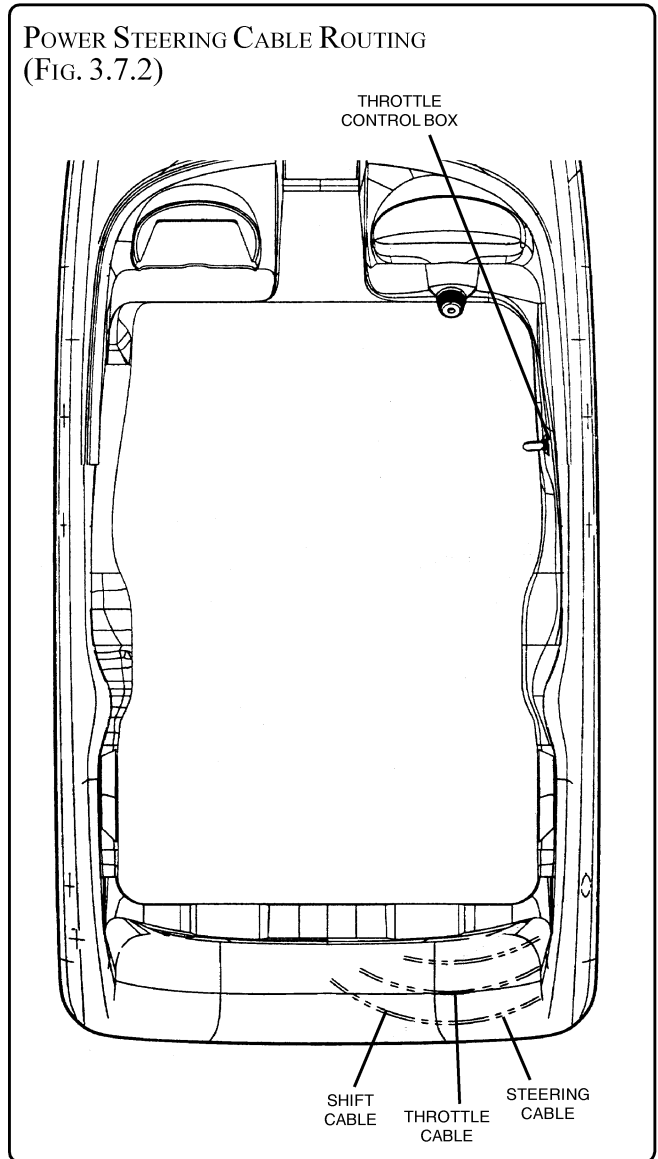

SECTION 3 • USING YOUR BOAT

THIS PAGE LEFT INTENTIONALLY BLANK



SECTION 4 • BILGE & UNDERWATER GEAR

1. BILGE

A. FUEL & OIL SPILLAGE

Regulations prohibit discharging fuel or oily waste in navigable waters. Discharge is defined as any action which causes a film, sheen or discoloration on the water surface, or causes a sludge or emulsion beneath the water surface. A common violation is bilge discharge. Use rags or sponges to soak up fuel or oily waste, then dispose of it properly ashore. If there is much fuel or oil in the bilge, contact a knowledgeable marine service to remove it. Never pump contaminated bilge overboard.

Fill fuel tank(s) less than rated capacity. Allow for fuel expansion.

B. DRAIN PLUG

! DANGER

Install and tighten drain plug before launching boat.

Boat will sink if drain plug is not in place and tight.

The bottom of the engine compartment is called the “bilge”. It is the lowest and inner part of the hull. Water and other liquids will collect here.

After removing your boat from the water, unthread the drain plug to drain the bilge (Figure 4.1.1).

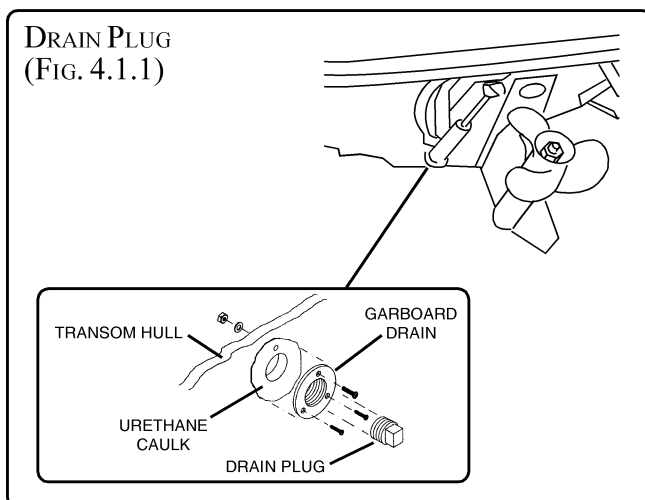

C. BILGE PUMPS

! WARNING

SINKING HAZARD – Ensure the bilge pumps are operating properly.

! CAUTION

Run bilge pumps in the manual position only as long as necessary to remove water. Running bilge pumps dry can damage the pump motor.

A bilge pump and float switch are located in the bottom of the bilge (Figure 4.1.2). The bilge pump is activated from the switch panel located on the helm (Figure 4.1.3).

BILGE PUMP & FLOAT SWITCH LOCATION & HOSE ROUTING (FIG. 4.1.2)

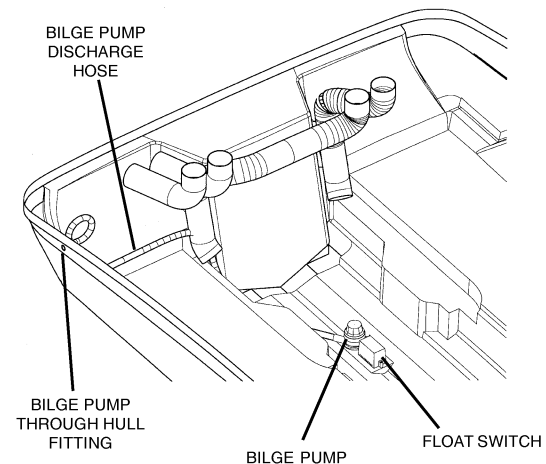

BILGE PUMP AND BILGE BLOWER SWITCH (FIG. 4.1.3)

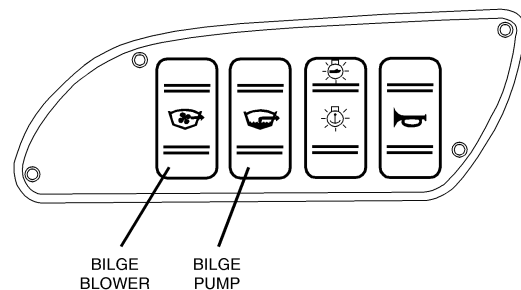

SECTION 4 • BILGE & UNDERWATER GEAR

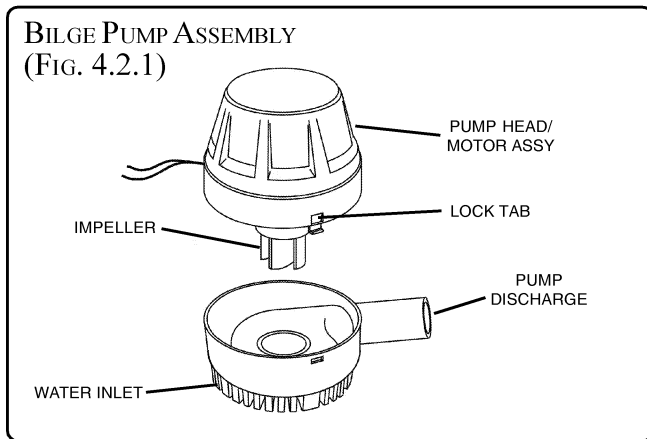

Before starting the engine, press the bilge pump switch so that the switch light comes ON. Make sure the pump is working by opening the engine compartment, listening to hear the pump running and check to see that liquid is being pumped out from the hull discharge (See Fig. 2.8.1). If the bilge has more liquid than normal, see Maintenance Section for locating and correcting the problem.

Except for checking the operation of the bilge pump using the ON position, leave the switch in the OFF (AUTO) position. In the OFF (AUTO) position, when the bilge liquid is deep enough to activate the float switch, the bilge pump turns on and pumps out the bilge liquid until the float switch drops and shuts off the pump.

If the liquid level in the bilge is higher than normal and the bilge pump empties the bilge when you use the ON switch, the float switch is not operating properly. Have it checked immediately. If the ON switch does not operate the pump, DO NOT use the boat until the problem is corrected.

The bilge pump is protected by a fuse in the fuse block located behind the control station (See Fig. 6.4.2).

1. MAINTENANCE

Frequently inspect the area under the float switches to ensure they are free from debris and gummy bilge oil. To clean, soak in heavy duty bilge cleaner for 10 minutes, agitating several times. Check for unrestricted operation of the float. Repeat the cleaning procedure if necessary.

Inspect the bilge pump intakes and keep them free of dirt or material which may impede the flow of water through the pump. To clean the pump strainer, depress the lock tabs on both sides of the pump and lift the pump motor.

D. BILGE BLOWERS

To prevent buildup of gasoline fumes to the explosive level in the engine compartment, the bilge blower must be run for at least four (4) minutes before starting the engine and kept running at all times when the engine is running to insure that there will be adequate ventilation when you are moving slowly.

The bilge blower is protected by a fuse in the fuse block located behind the control station (See Fig. 6.4.2).

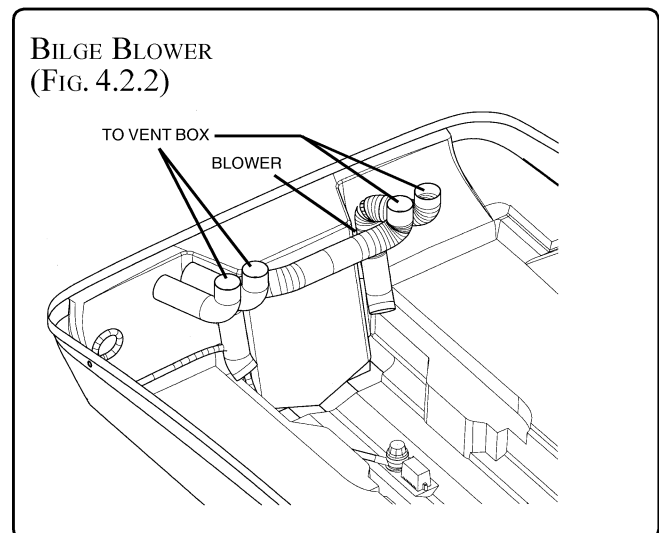

SECTION 4 • BILGE & UNDERWATER GEAR

! WARNING

EXPLOSION/FIRE HAZARD – Run blower at least four (4) minutes before starting engine or generator. Check bilge and engine compartment for fumes.

! WARNING

Do not allow obstructions to interfere with bilge blower or ventilation intake operation. Engine performance may be adversely affected.

E. ENGINES AND STERN DRIVE

1. MAINTENANCE AND SERVICE

Engine failure away from shore can be dangerous. You must follow the recommended maintenance schedule to best ensure trouble-free operation of your engine and stern drive.

2. VIBRATION & CAUSES

Some vibration is to be expected in your boat because of the action of the engines and the propeller. But excessive vibration indicates conditions which must be promptly corrected to avoid damage. The following are some conditions which may cause vibrations.

- Weeds, ropes, fishing lines, nets or your own trailing lines can become wrapped around the propeller and/or shaft, causing vibration and loss of speed. Always stop the boat, make sure it is clear to the rear, and then reverse the propeller after going through a weedy area to unwrap and clear away any weeds which may have accumulated. If this doesn't clear the entanglement, and you can't anchor or moor the boat in shallow water to get to the stern drive in the water, the boat will have to be taken out of the water.
- A badly damaged or distorted propeller or shaft is an obvious cause of vibration. Run at slow speed to shore. REPLACE IMMEDIATELY.
- If the engine mounts fail and the engine can contact the hull while it is running, vibration will

be felt. Run at slow speed to shore. REPLACE IMMEDIATELY.

3. IMPACT TO STERN DRIVE

The stern drive can be damaged by impact, either while trailering or boating. To minimize the possibility of impact damage while trailering, keep the stern drive raised to the trailering position.

The hydraulic system used to raise and lower the stern drive can cushion impact and lessen damage from head-on impacts to the stern drive from underwater objects BUT ONLY when the boat is moving forward. There is no protection if the stern drive is struck during reverse operation or from an angle when moving forward.

If you strike a submerged object, STOP THE ENGINE as soon as possible and examine the stern drive unit for damage. Even if no damage is visible, there could be internal problems or difficulty maneuvering. If you must use the boat after impact, run at the lowest speed possible.

4. PROPELLER REMOVAL AND INSTALLATION

! WARNING

If engine is started during propeller maintenance, serious personal injury can occur.

Shut off engine, remove key, shift into neutral, and put tape over ignition switch key slot.

- a. Shut off engine, remove key, shift into neutral and put tape over ignition switch key slot.
- b. Straighten the bent tabs on the propeller nut retainer (Figure 4.3.1).

PROPELLER
(FIG. 4.3.1)

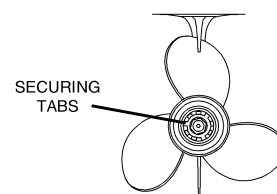

SECTION 4 • BILGE & UNDERWATER GEAR

- c. Place a block of wood between the gear case and propeller to stop propeller from rotating and remove propeller nut (Figure 4.4.1).

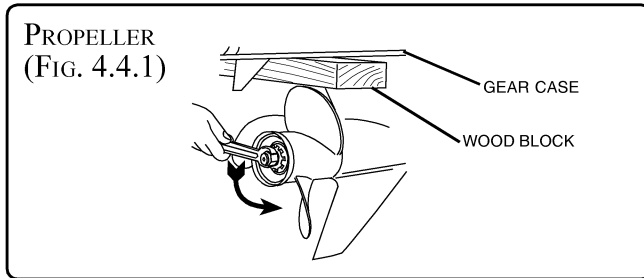

- d. Remove the propeller nut retainer, the thrust hub and the continuity washer (Figure 4.4.2) and put them in a secure place. Pull the propeller straight off the shaft. Remove the thrust washer that is behind the propeller. If the propeller is seized to the shaft and cannot be removed by hand, special tools are needed. Have the propeller removed by an authorized dealer or trained mechanic.
- e. Coat the propeller shaft with an anti-seize lubricant (Figure 4.4.3).

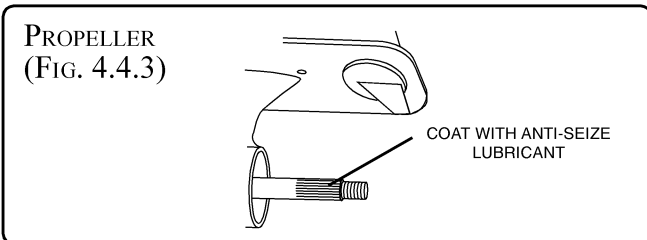
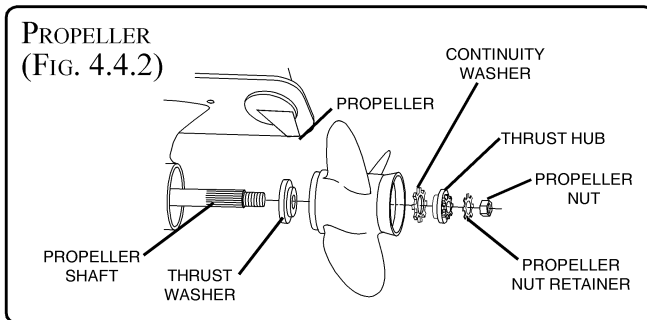

- f. Install the thrust washer, propeller, continuity washer, thrust hub, propeller nut retainer and the propeller nut onto the shaft (Figure 4.4.2).
- g. Place a block of wood between the gear case and the propeller (Figure 4.4.4) and torque the propeller nut to recommended manufacturer's specifications. The correct propeller nut torque is given in your Engine Operator's Manual in the Owner's Manual Packet.

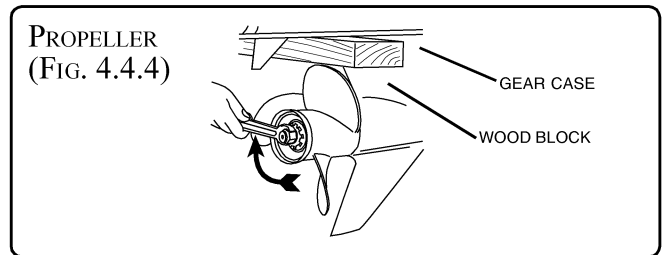

- h. Secure the propeller nut by bending three (3) of the tabs of the propeller nut retainer into the thrust hub grooves (Figure 4.4.5).

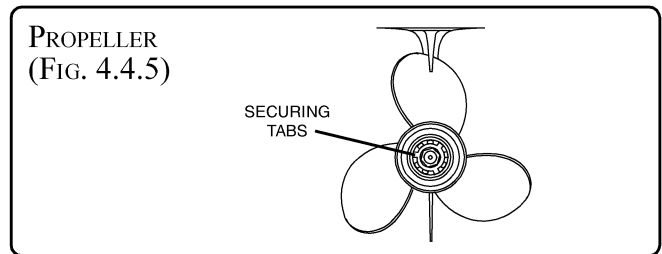

SECTION 4 • BILGE & UNDERWATER GEAR

F. BILGE LAYOUT

BILGE LAYOUT
(FIG. 4.5.1)

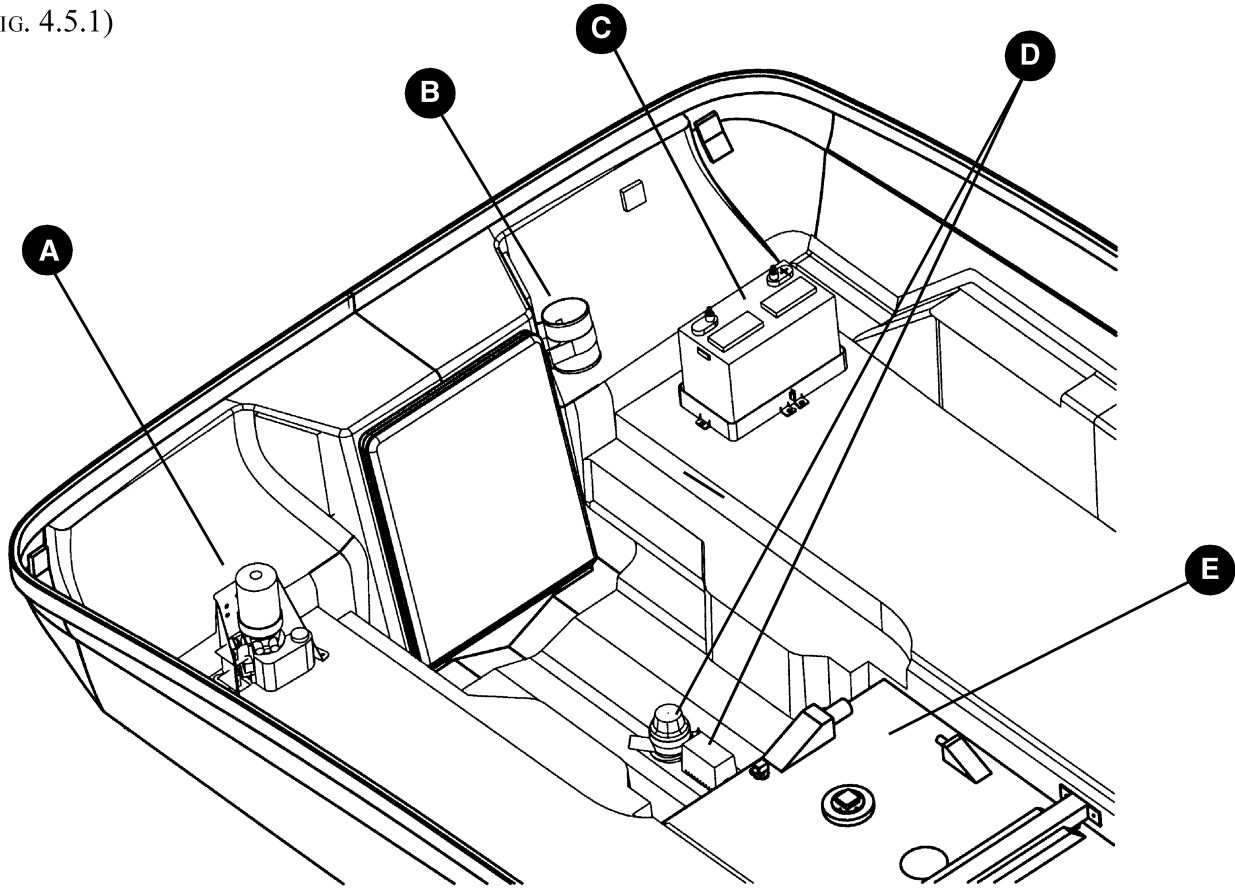

- A Power Trim Pump
- B Bilge Blower
- C Battery & Battery Tray
- D Bilge Pump and Float Switch
- E Fuel Tank

SECTION 4 • BILGE & UNDERWATER GEAR

THIS PAGE LEFT INTENTIONALLY BLANK



SECTION 5 • FUEL SYSTEM

1. FUEL SYSTEM

Section 3 - Using Your Boat contains important fueling information. Take time to read all the fuel related information in the owner's manual.

The 185 Sport standard gasoline fuel system consists of a 26 gallon (98.4 liters) fuel tank, fuel tank vent, an anti-siphon valve, engine fuel supply line and fuel fill (Figure 5.1.1).

The fuel tank vent serves as a pressure/vacuum release and safety overflow. The fuel vent is located inside the fuel cap on the port side of the hull.

Periodically check the vent to assure it is not clogged (Figure 5.1.1).

The gasoline engine fuel pick-up at the fuel tank has an anti-siphon valve to prevent fuel from siphoning out in the event of fuel line failure.

CAUTION

Never start an engine until you are certain that fuel fumes are not present in the engine compartment or elsewhere in the boat.

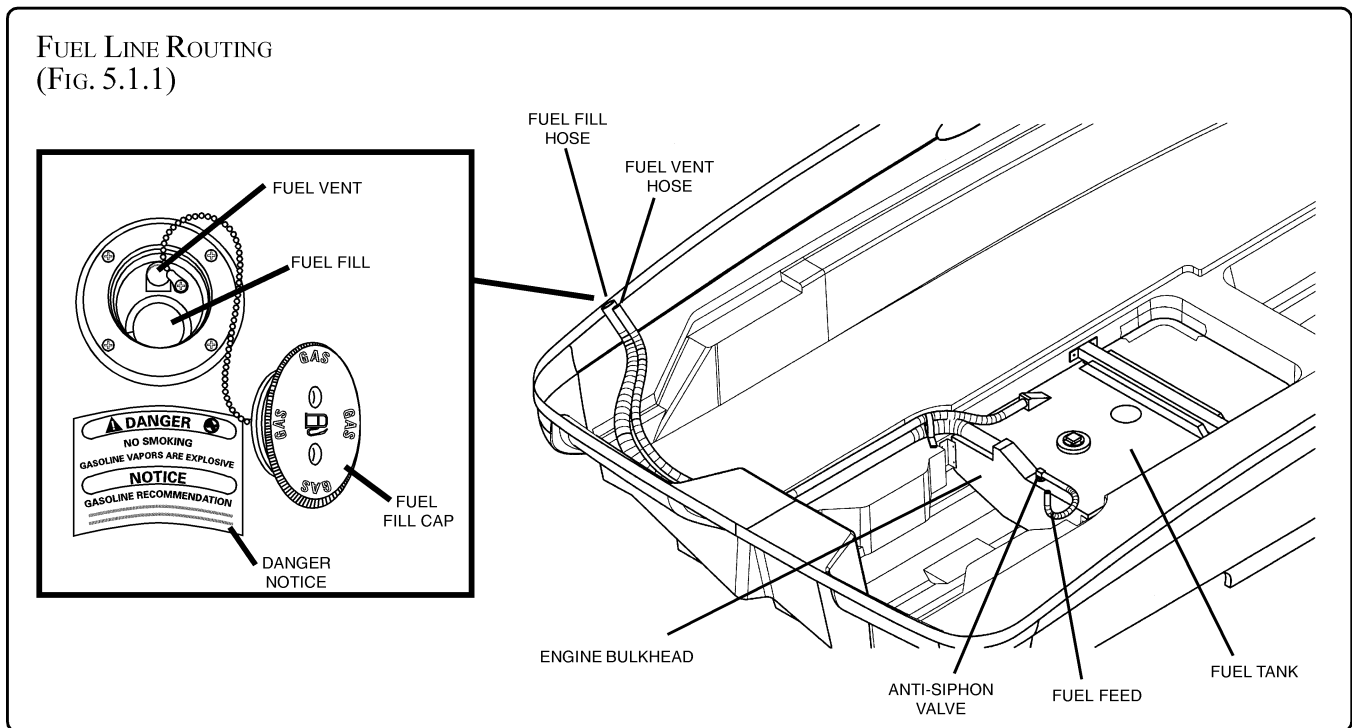

A. ANTI-SIPHON VALVE (INBOARD/OUTBOARD ENGINE ONLY)

The fuel pick-up at the fuel tank has an anti-siphon valve to prevent fuel from siphoning out in the event of line failure (Figure 5.1.2). In an emergency situation, remove the anti-siphon valve if the engine is not getting fuel.

NOTE: Replace with new anti-siphon valve or fuel shut off valve as soon as possible as anti-siphon protection is required by federal law.

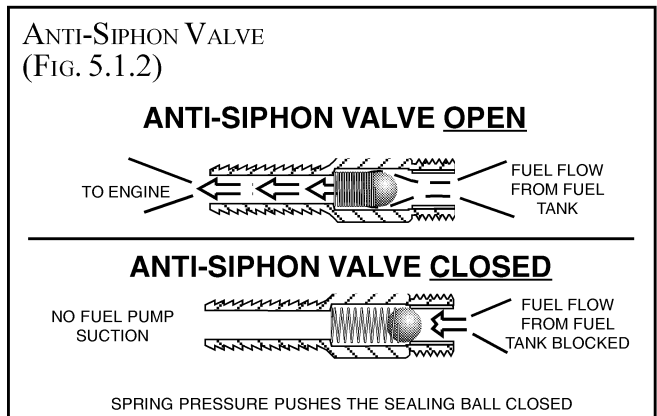

SECTION 5 • FUEL SYSTEM

2. FUELING PRECAUTIONS

Certain precautions must be carefully and completely observed every time a boat is fueled, even with diesel fuel. Diesel fuel is nonexplosive but it will burn.

A. GENERAL:

- Fuel during daylight.
- Check fill plate label to ensure fuel is placed only in fuel tank. Fuel fill plate is located on the aft port side of the hull (see Fig. 5.3.1).
- Avoid spills.
- Know your fuel capacity and consumption. Record the amount of fuel used since your last fill up, and compute the engine's hourly fuel usage. As a fuel gauge backup check, deduct the average hourly fuel usage from fuel tank capacity.
- Observe the "Rule of Thirds": one-third fuel for trip out, one-third for return and one-third for reserve.
- Allow an additional 15 percent fuel reserve when operating in rough seas.

B. BEFORE & DURING FUELING – CHECKLIST:

- Fire extinguisher – close at hand.
- Mooring – boat tied securely to fueling pier.
- Crew – at least one knowledgeable person present.
- Passengers – unnecessary people off the boat.

- Engines – stopped.
- Electrical equipment, including blowers – power off.
- Windows, doors, hatches – closed. (if applicable)
- Smoking material – extinguished.
- Inboard tanks – grounded.
- Filler pipe – marked GAS.
- Fuel nozzle – in contact with filler pipe to prevent static sparks.
- Fill level – fill less than rated capacity of tank; allow for fuel expansion.
- Trim – fuel weight distributed equally.

C. AFTER FUELING – CHECKLIST:

- Windows, doors, hatches – open. (if applicable)
- Sniff test – if fuel fumes remain, operate blowers until fumes are gone.
- Fuel tank – secure filler cap.
- Spills – wipe; dispose of rags ashore.



SECTION 5 • FUEL SYSTEM

FUEL FILL LOCATION
(FIG. 5.3.1)

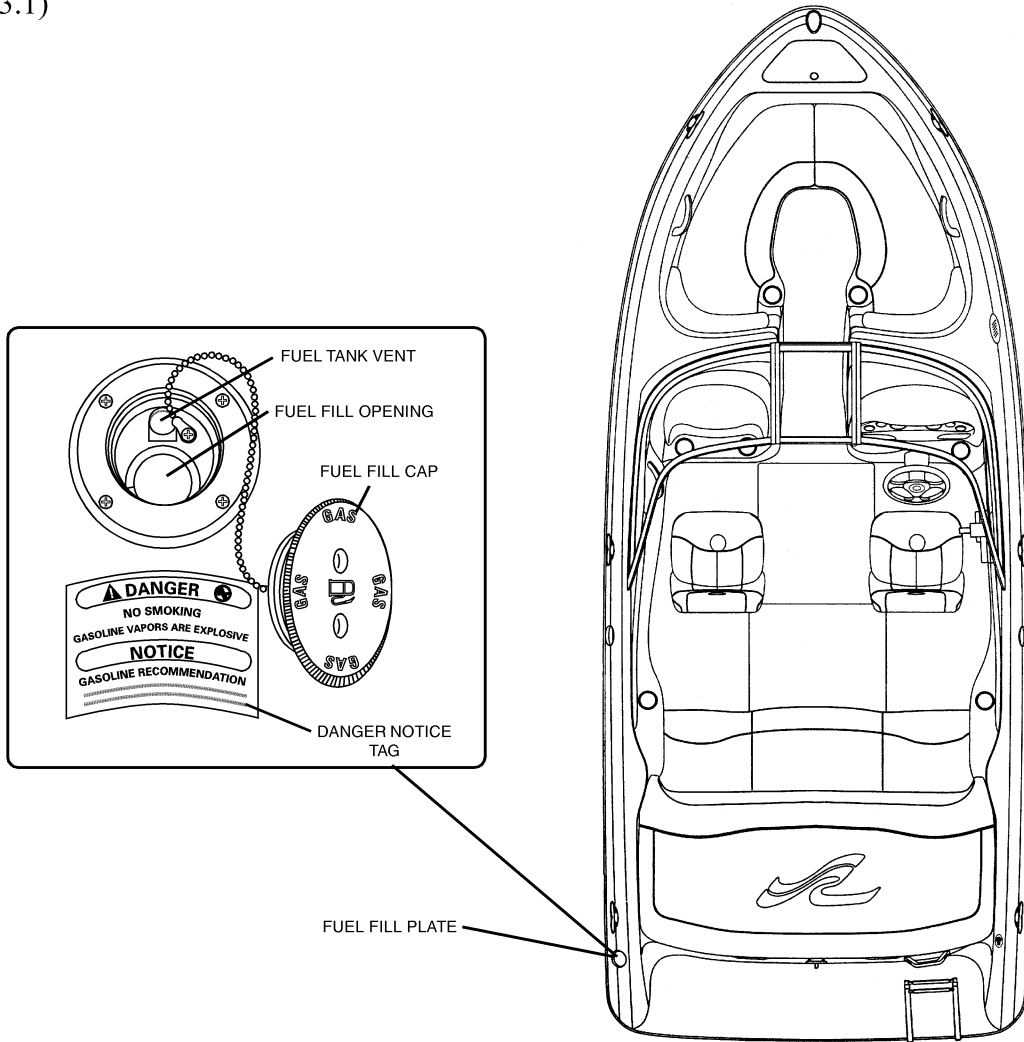

SECTION 5 • FUEL SYSTEM

THIS PAGE LEFT INTENTIONALLY BLANK



SECTION 6 • ELECTRICAL SYSTEM

1. ELECTRICAL SYSTEM

A. DIRECT CURRENT (DC)

The 12 volt direct current (DC) electrical system (similar to that in your car or truck) derives its power from the battery. An engine-driven alternator keeps the battery in a charged condition. The battery voltage is indicated by the voltmeter on the helm panel. The negative terminal of the battery is attached to one of the ground studs of the engine. This is designated as the engine negative terminal.

Ask your dealer for a careful analysis of DC power needs on your boat. It may be necessary to add batteries or auxiliary charging methods to supply adequate power for any additional accessories you wish to add.

BATTERIES

**DANGER**

DO NOT USE JUMPER CABLES IN THE ENGINE COMPARTMENT.

They can cause an explosion from sparks.

**DANGER**

A battery will explode if a flame or spark ignites the free hydrogen given off during charging.

Never use an open flame or strike sparks in the battery area.

The battery installed in your boat has been selected for its ability to furnish starting power based on engine starting requirements, as well as its ability to power the DC accessories attached to the electrical system. Your Engine Owner's Manual indicates the recommended battery for the engine installed in your boat.

**CAUTION**

To prevent arcing or damage to the alternator, always disconnect battery cables before doing any work on the engine's electrical system.

To remove the battery cables:

1. Turn off all items drawing power from the battery.
2. Turn the battery switch to the OFF position (Battery switch is optional equipment on some models).
3. Remove the negative cable first, then the positive cable. To replace the cables, first replace the positive cable, then the negative.

BATTERY MAINTENANCE

- Check the fluid levels in the cells approximately every 4 weeks, and weekly in summer and hot zones.
- The fluid level must be between the lower and upper markings.
- Replenish only with distilled water. Do not use metal funnel.
- Coat battery terminal clamps with silicone grease. Keep batteries clean and dry.

Battery life is shortened if it is drained to zero charge before recharging. It is recommended that a battery not be discharged more than 50 percent. If the battery does become run down, recharge it as soon as possible.

Running the engine to recharge the battery may not be effective. The alternator only creates charging power at higher engine speeds, so simply idling or trolling will not generate enough power to recharge the battery.

If you need to charge a battery, use only a battery charger designed to charge automotive/marine batteries. Use charger only when batteries are disconnected from the boat's electrical circuit. Follow the charger instructions.

If your boat will not be used for several weeks remove the batteries from the boat and connect them to a charger.



SECTION 6 • ELECTRICAL SYSTEM

BATTERY CABLE ROUTING
(FIG. 6.2.1)

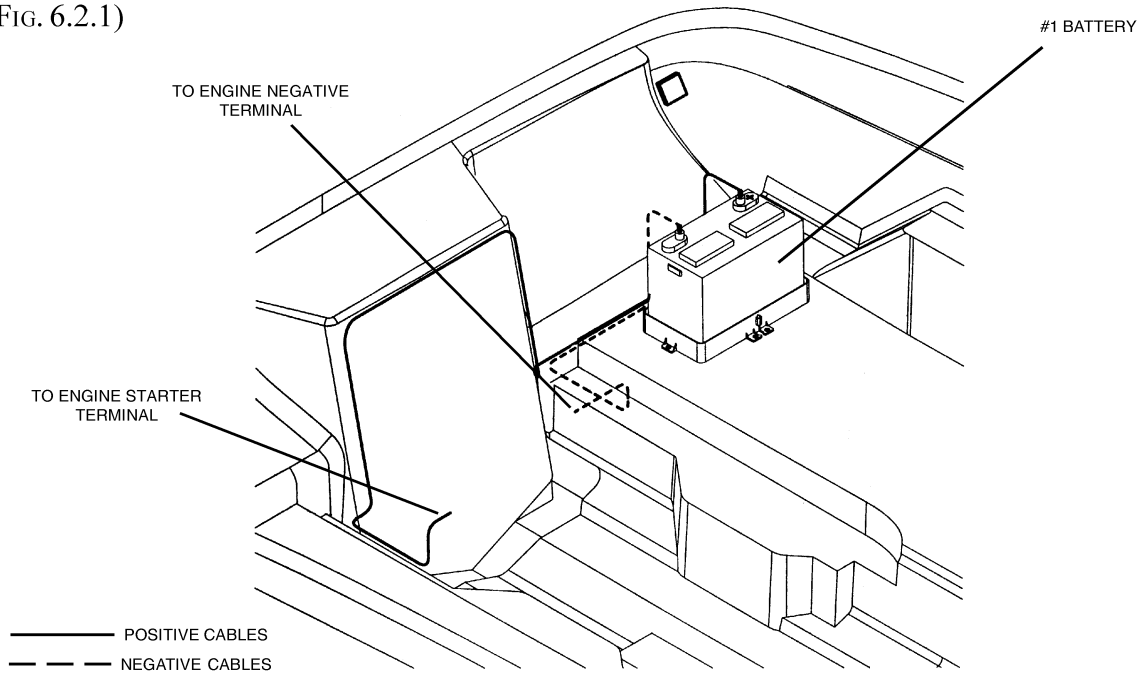

BATTERY CABLE ROUTING WITH BATTERY
SWITCH OPTION
(FIG. 6.2.2)

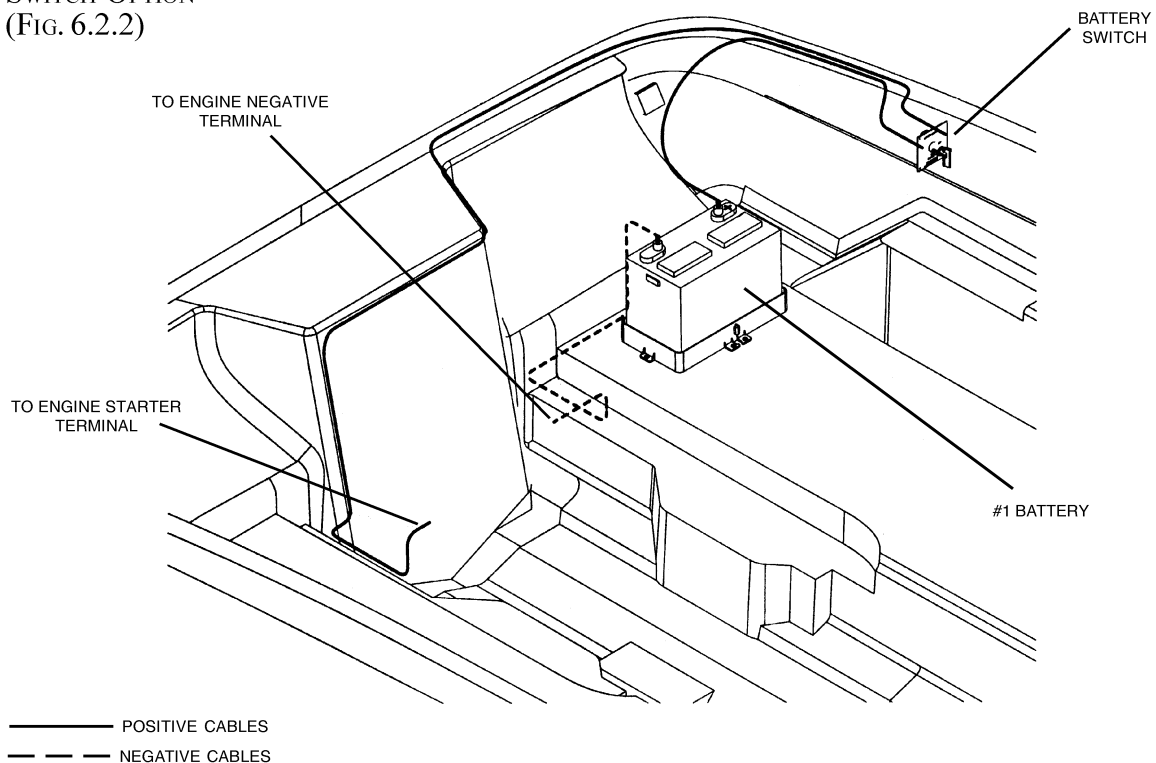

SECTION 6 • ELECTRICAL SYSTEM

B. BATTERY SWITCH

The battery switch (Figure 6.3.1) controls the delivery of DC power from the battery to the engine and all equipment, lights and accessories using DC power. The battery switch is located on the aft wall of the storage space in the port side of the cockpit (Figure 6.3.2).

NOTE: The bilge pump and stereo memory are not shut off by the battery switch. This is to permit the bilge pump to operate at any time excess fluid accumulates in the bilge, which can occur when the boat is docked and unattended. The entire remaining DC system is turned off with the battery switch.

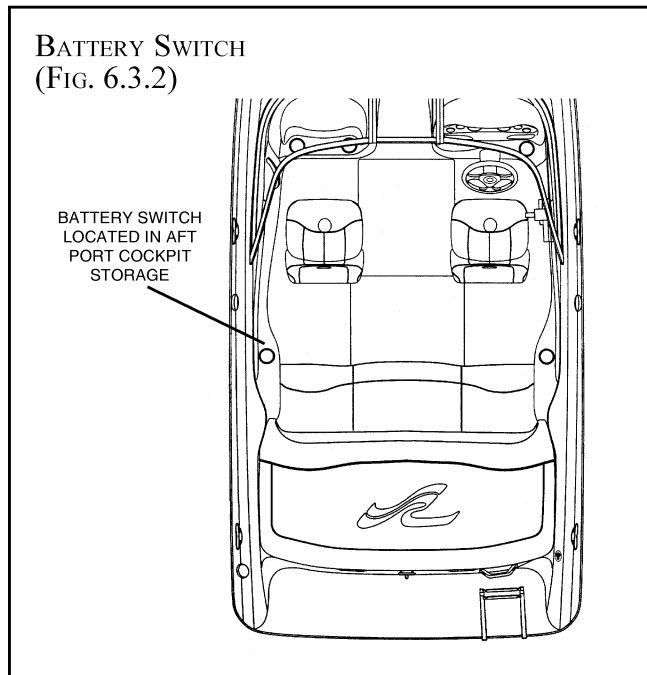
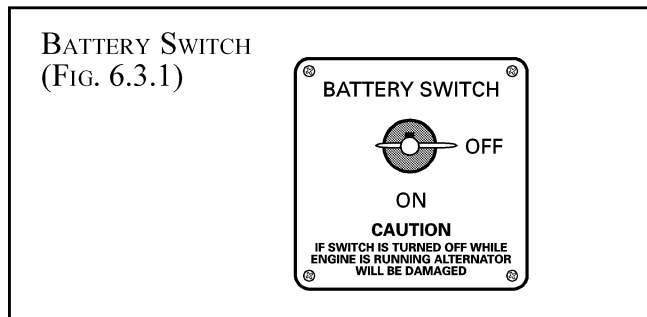

2. IGNITION PROTECTION

All electrical components in the engine compartment must be ignition-protected to avoid the possibility of creating sparks in a gasoline environment.

Protective terminal covers, such as rubber boots on electrical connections, must be in place at all times except when servicing equipment.

Jumper cables are not ignition-protected. **DO NOT USE** jumper cables in the engine compartment. The engine compartment may accumulate dangerous explosive gasoline fumes/vapors and hydrogen gas from batteries being charged. A spark produced when connecting a jumper cable can cause an explosion.

! DANGER

GASOLINE VAPORS CAN EXPLODE

Use **ONLY** Marine-rated parts to replace such items as starters, distributors, alternators, generators, etc.

Do not use automotive parts for these components or any jumper cables because they are not ignition-protected and could cause a fire or explosion.



SECTION 6 • ELECTRICAL SYSTEM

3. FUSES

If you need to replace a fuse, **use only the same amperage as the original**. It is recommended that you carry spare fuses. See Fig 6.4.2 for the proper fuse sizes.

If a fuse is replaced with one of lower amperage, it will not be sufficient to carry the electrical load of the equipment it is connected to and will cause nuisance fuse failure or breaker tripping.

If a fuse is replaced with one of higher amperage, it will not provide adequate protection against an electrical malfunction and will create a fire hazard.

The fuses (Figure 6.4.1) are color coded according to the amperage and the rating is also marked on each fuse.

! WARNING

Use of higher amperage fuses or breakers is a fire hazard.

Use fuses and breakers having the same amperage rating as the original or as specified.

FUSE CONDITION (ATO TYPE FUSE)
(FIG. 6.4.1)

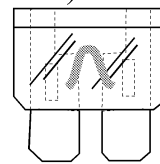

GOOD FUSE

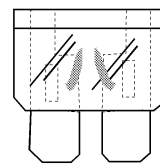

BLOWN FUSE

ACCESSORY FUSE BLOCK (LOCATED BEHIND DASH ACCESS PANEL)
(FIG. 6.4.2)

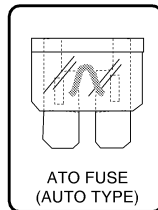
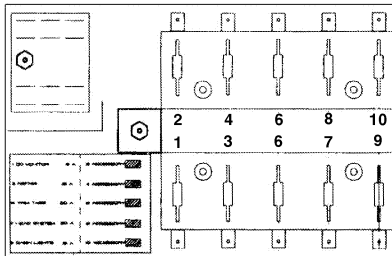

FUSE NAME

FUSE AMPERAGE 12VDC

1. HORN	5
2. IGNITION	15
3. NAV LTS	5
4. BLOWER	7.5
5. WIPER	*BLANK
6. BILGE PUMP	3
7. ACCESSORY	*BLANK
8. 12V RECEPTACLE	15
9. ACCESSORY	*BLANK
10. ACCESSORY	*BLANK

*FOR DEALER OR CUSTOMER
INSTALLED EQUIPMENT



SECTION 6 • ELECTRICAL SYSTEM

4. 12 VOLT ACCESSORY RECEPTACLE

Your boat has a 12 volt accessory receptacle on the helm panel. The receptacle is a cigarette lighter style jack that may be used with most 12 volt accessories using this type of plug.

Note: This receptacle is not designed for a cigarette lighter. Do not try to insert a cigarette lighter into this receptacle.

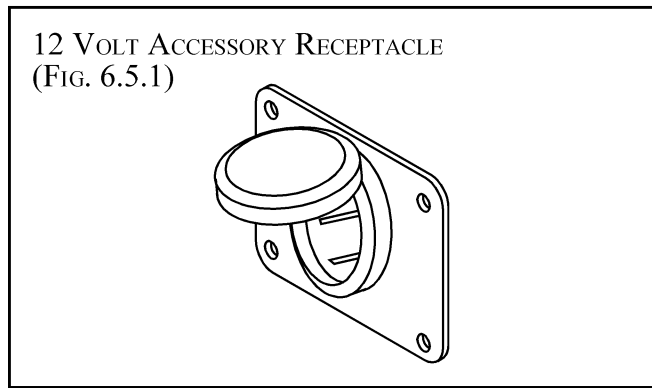

5. LIGHTING

Your boat is equipped with a variety of different lighting fixtures. **Always replace a bulb using the type and wattage of the original bulb.**

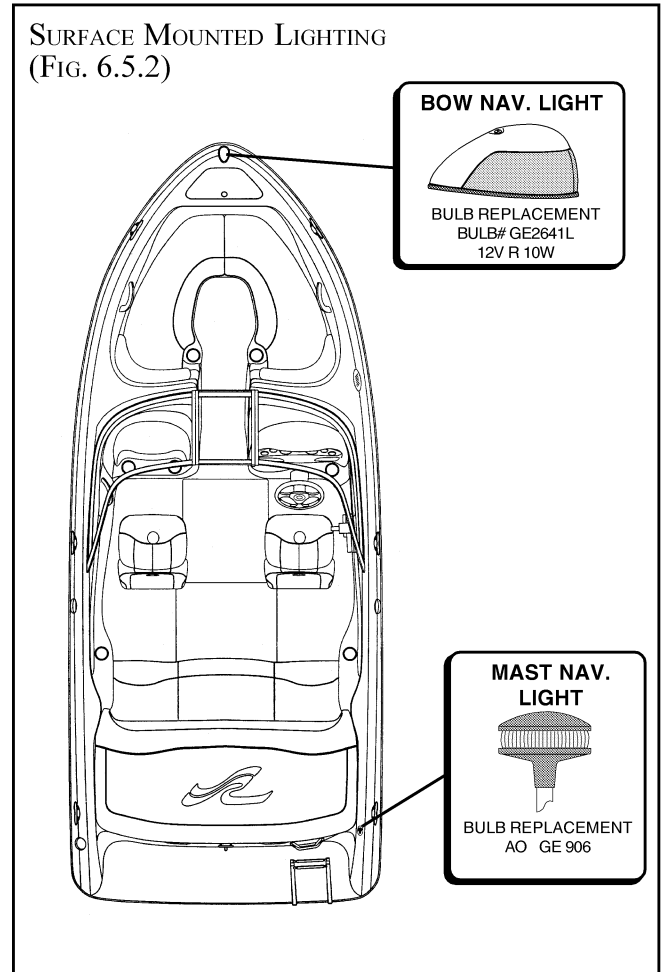

SECTION 6 • ELECTRICAL SYSTEM

6. ELECTROLYTIC CORROSION AND ZINC ANODES

Electrolytic corrosion of metals on power boats can result in rapid and serious deterioration of metal parts. You must set a regular schedule and look for the possibility of electrolytic corrosion (the deterioration of metals due to dissimilar characteristics when placed in salt water). It is your responsibility to check for and replace parts damaged due to electrolytic corrosion.

NOTICE

DO NOT PAINT BETWEEN THE ZINC AND THE METAL IT CONTACTS, AND DO NOT PAINT OVER THE ZINC.

To minimize electrolytic corrosion of the metals on your boat, zinc anode plates are provided to protect underwater hardware. Zinc, being much less “noble” than the copper-based alloys and aluminum used in underwater fittings, will deteriorate first and protect the other metals.

Stern drives are fitted with zinc anodes on their lower units (refer to your Engine Owner’s Manual for their locations). If your boat is equipped with trim tabs, zinc plates are installed on each of the trim tabs (Figure 6.7.1). If the boat is equipped with a Mercathode® the stern drive will not have a zinc anode.

Zinc anodes require replacement about every six months if the boat is operated in salt water. In fresh water, the zinc anodes can be replaced about once a year.

If the anodes deteriorate more rapidly than this, there is probably a stray current problem within the boat or at the slip or mooring.

If the anodes do not deteriorate, they are not protecting the other metallic parts of your boat. This can be caused by loose anodes or by low grade zinc or by not having a solid electrical contact between the anode and the metal it contacts, or by paint on the anode.

If the anodes are deteriorating rapidly, or not at all, contact your dealer.

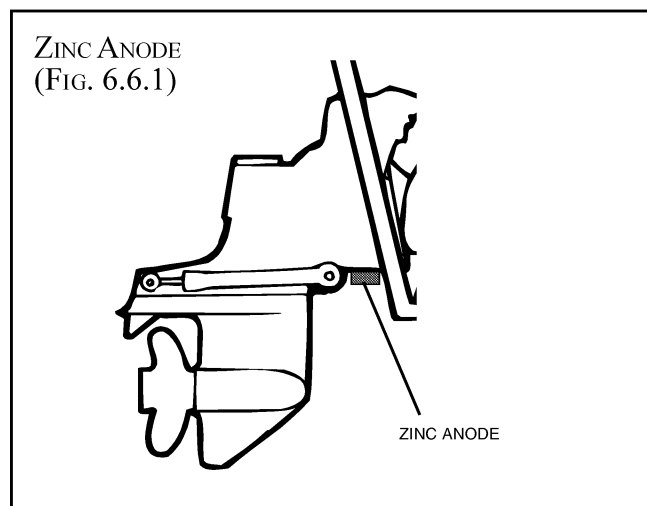

SECTION 6 • ELECTRICAL SYSTEM

7. WIRE HARNESSES

WIRE HARNESS
(FIG. 6.7.1)

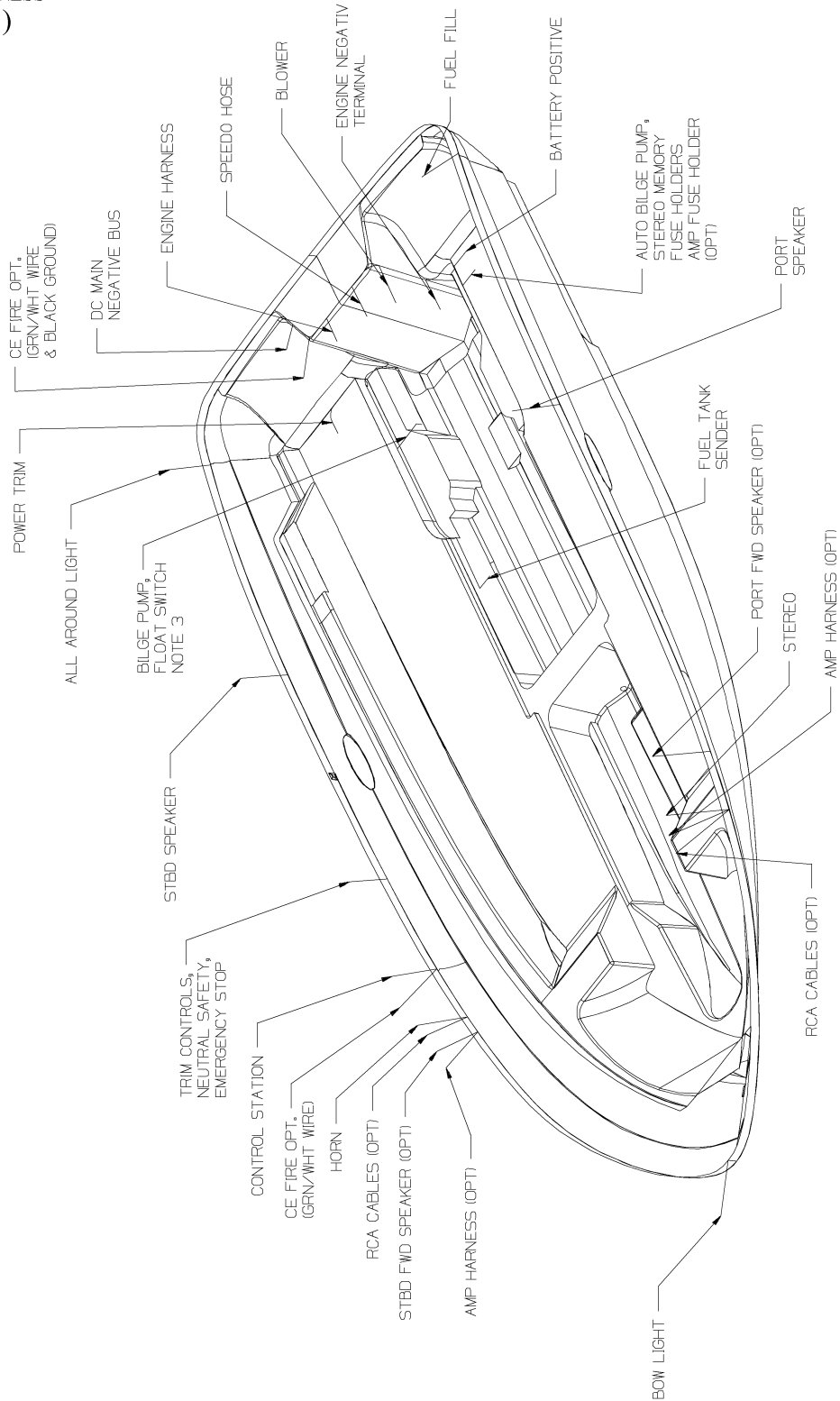

SECTION 6 • ELECTRICAL SYSTEM

THIS PAGE LEFT INTENTIONALLY BLANK



8. 185 Sport Electrical Schematics

DC WIRING DIAGRAM
(Fig. 6.9.1)

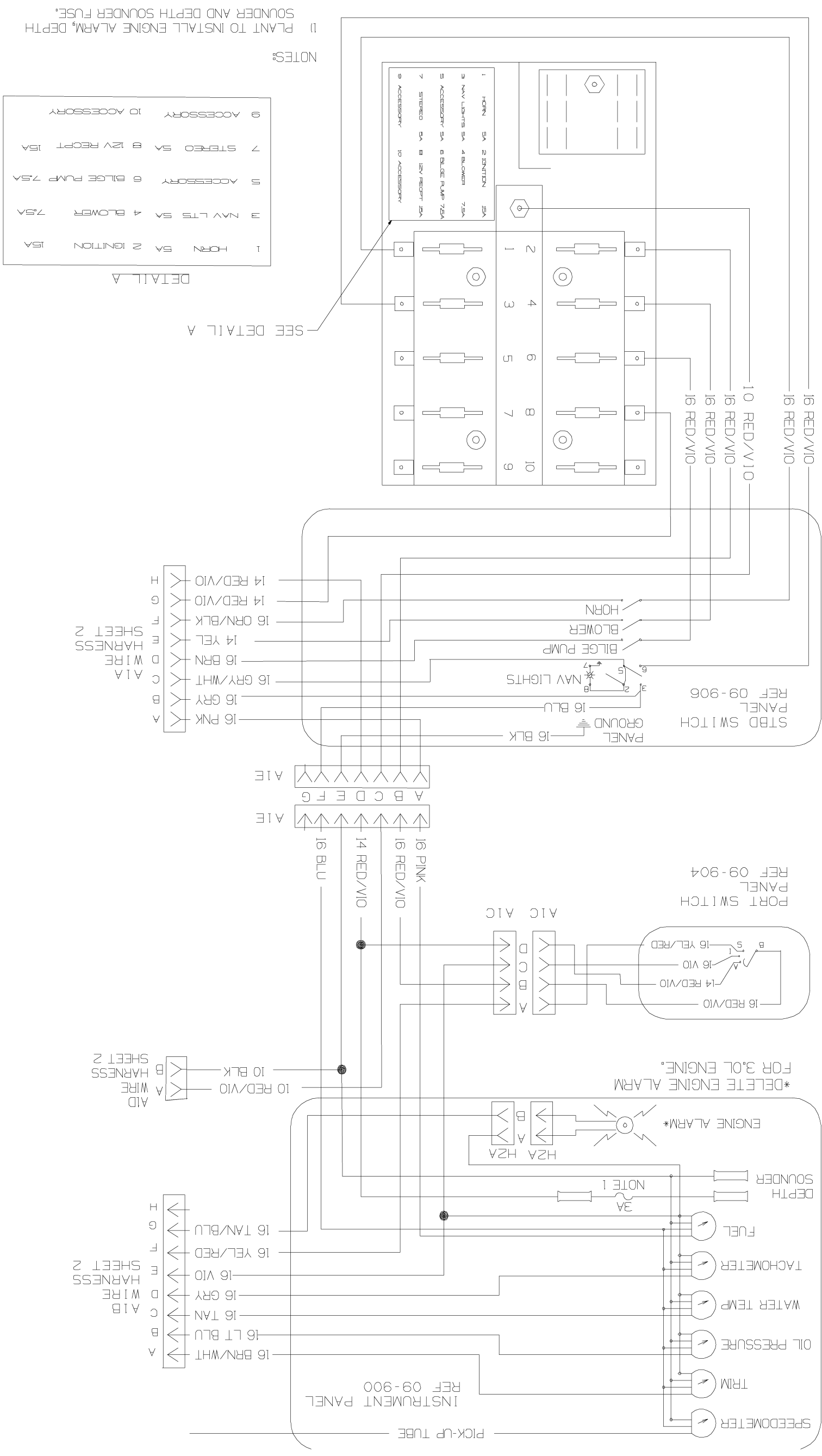

DRAWING NO. 09-601 (1 OF 2) REVISION 04



185 Sport Electrical Schematics

DC WIRING DIAGRAM
(Fig. 6.10.1)

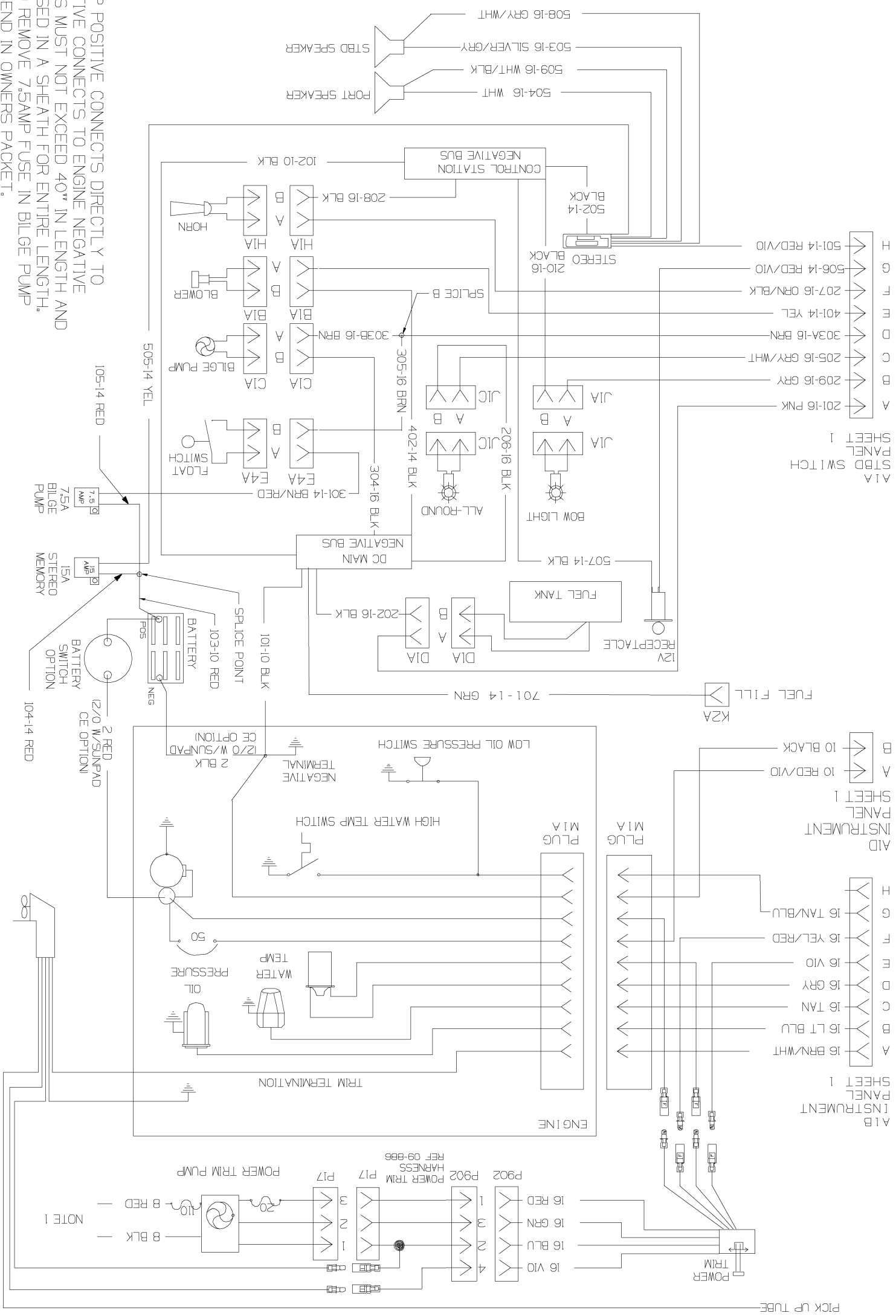

NOTES:

- 1) POWER TRIM PUMP POSITIVE CONNECTS DIRECTLY TO STARTER. NEGATIVE CONNECTS TO ENGINE NEGATIVE TERMINAL. LEADS MUST NOT EXCEED 40" IN LENGTH AND MUST BE ENCLOSED IN A SHEATH FOR ENTIRE LENGTH.
- 2) 182BR PLANT TO REMOVE 7.5AMP FUSE IN BILGE PUMP FUSE HOLDER. SEND IN OWNERS PACKET. 1825RX FLOAT SWITCH IS STANDARD.

DRAWING NO. 09-601 (2 OF 2) REVISION 05



SECTION 7 • OPTIONS & ACCESSORIES

1. BOAT LAYOUT AND ACCESSORY LOCATIONS

Figure 7.1.1 and 2.4.1 through 2.7.1 show the location and arrangement of the most important equipment and components on your boat. Using these drawings, walk through your boat, locate the features shown, and become familiar with their operation and maintenance.

2. CANVAS (OPTION)

DANGER

If the cockpit is totally enclosed with canvas covers and curtains while the engine is running or boat is moving, carbon monoxide will build up and cause death or permanent injury.

Do not use the rear (aft) curtain or camper top while engine is running or boat is moving.

The Bimini Top or sunshade should not be used when the vessel speed exceeds 45 MPH. Damage to the boat or Bimini may occur.

DO NOT have Bimini Top installed when trailering. Damage to boat or Bimini may occur. Use cockpit cover ONLY when trailering.

Attached to the inside of the Bimini Top is a DANGER tag for Carbon Monoxide Gas (CO) buildup and a WARNING tag for limiting speeds when Bimini Top canvas is installed. The rear (aft) curtain also has a WARNING tag stating “The Aft

DANGER

Exhaust fumes from engines contain deadly carbon monoxide gas (CO). Boats enclosed with canvas or with poor ventilation are most likely to collect fumes.

CO sickness symptoms include headache, nausea and dizziness. Do not mistake these symptoms for sea sickness.

Ventilate boat. See Section 1.4, Carbon Monoxide, for more details.

Curtain must not be used while engine is running or boat is underway”. If your canvas does not have these tags, they become lost or are unable to be read, contact your dealer for replacement labels.

For your safety, decide which canvas pieces you want to remove or install before you leave the boat slip or off-load your boat from the trailer into the water. Removing or installing canvas on the water can be difficult since rough water or wakes can cause you or your passengers to lose their balance while attempting canvas removal or installation.

For safety and ease of installation and removal of canvas, use at least two people. Know which canvas piece(s) that you are to install or remove.

DANGER

In rainy weather and/or cold weather, fresh air must circulate through boat to avoid carbon monoxide poisoning.

See Section 1.4, Carbon Monoxide, for more details.

The following canvas options are available:

- Bimini Top and Boot
- Cockpit/Tonneau Cover
- Tonneau Cover



SECTION 7 • OPTIONS & ACCESSORIES

CANVAS
(FIG. 7.2.1)

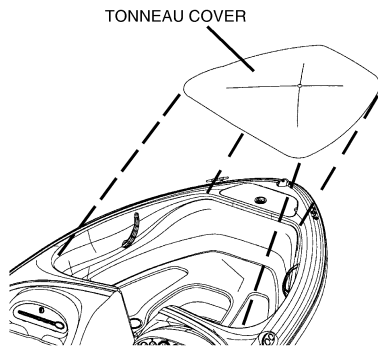
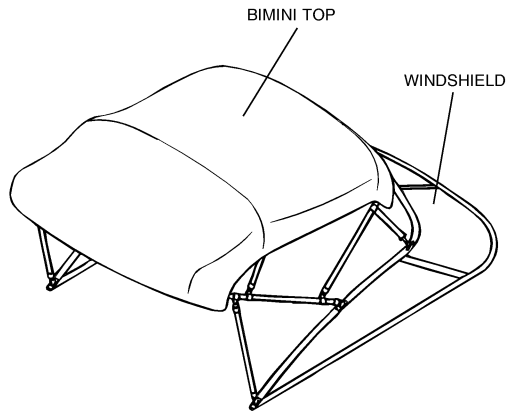

A. INSTALLATION TIPS

- Adjustable Support Rods: Adjustable support rods are located on the Convertible and Bimini Top. There is an outside tube and an inside tube. Push in the button to adjust for longer or shorter rod lengths.

B. TRAILERING WITH CANVAS

The Bimini Top must be removed when trailering. Damage will occur to canvas and to the metal rods (bows) or boat if attached to boat while trailering.

C. CANVAS CARE AND MAINTENANCE

See Section 9, for instructions on the care and maintenance of your canvas.

SECTION 8 • REQUIRED INSPECTION, SERVICE AND MAINTENANCE

Routine inspection, service and maintenance of your boat's systems are vital to assure your safety, as well as for prolonging the life of your boat. You should develop regular routines for inspecting your boat. The chart below summarizes inspection, service and maintenance activities. This section also contains descriptions of some convenient methods for evaluating the condition of some of your boat's systems.

The interval between necessary service or maintenance is highly variable, depending on the environment your boat is in, and on the severity of operating conditions. For example, corrosion of parts on boats operated in salt water proceeds much faster than the corrosion of parts on a boat operated in fresh water. The intervals listed below are recommended maximums, and you must reduce the time between inspections if your observations indicate the need.

1. SUMMARY GUIDE FOR INSPECTION, SERVICE AND MAINTENANCE

ITEM	REQUIRED MAINTENANCE/SERVICE	REFERENCE SOURCE	INTERVAL				
			BEFORE EVERY USE	AFTER FIRST 20 HOURS	EVERY 25* OR 50 HOURS	EVERY 50* OR 100 HOURS	EVERY 6 MOS. OR ANNUALLY
Battery	Check water level	Owner's Manual p. 6.1	•	•	•		
Bilge Area	Clean and check	Owner's Manual p. 4.1					•
Bilge Blowers	Hose connections tight	Owner's Manual p. 4.2			•		•
Bilge Pump	Float switch operates freely	Owner's Manual p. 4.1					•
Canvas	Clean	Owner's Manual p. 9.2	As Needed				
Controls							
<i>Steering</i>	Check for proper operation		To be done by Sea Ray dealer every six months				
	Power steering oil level	Engine Manual	•				
<i>Throttle</i>	Lubricate. Include all shift linkage and pivot points	Engine Manual		•		•	•
Electrical							
<i>Connections</i>	Check for looseness		To be done by Sea Ray dealer annually				
**GFCI (120V) Outlet	Check for operation	Not on this boat					•
Engine							
<i>Alarm</i>	Check	Engine Manual	•				
<i>Cooling System</i>	Check for leaks	Engine Manual	•				
<i>Connections</i>	with engine running						
<i>Crankcase ventilating system</i>	Clean	Engine Manual		•		•	
<i>Drive belts</i>	Check	Engine Manual	•				
<i>Exhaust System</i>	Check for leaks	Engine Manual	•	•		•	
<i>Flame Arrestor</i>	Clean	Engine Manual		•		•	
<i>Fuel Filter</i>	Replace	Engine Manual				•	
<i>Mounts (Fasteners)</i>	Tighten	Engine Manual		•			•
<i>Oil and Filter</i>	Replace	Engine Manual				•	•
<i>Oil Level</i>	Check	Engine Manual	•				
Fuel System							
<i>Connections & Lines</i>	Check for leaks	Engine Manual	•	•	•		
<i>Tanks</i>	Check for leaks	Engine Manual	•	•	•		
<i>Water Separating Fuel Filter</i>	Replace	Engine Manual		•			•

*Use in salt water or other severe operating conditions requires shorter maintenance/service intervals

**May not be on your boat



SECTION 8 • REQUIRED INSPECTION, SERVICE AND MAINTENANCE

SUMMARY GUIDE FOR INSPECTION, SERVICE AND MAINTENANCE

ITEM	REQUIRED MAINTENANCE/SERVICE	REFERENCE SOURCE	INTERVAL				
			BEFORE EVERY USE	AFTER FIRST 20 HOURS	EVERY 25* OR 50 HOURS	EVERY 50* OR 100 HOURS	EVERY 6 MOS. OR ANNUALLY
Propeller	Inspect for damage		Always after striking object				
Seaworthiness							
<i>Bilge drain plug</i>	Installed and tight	Owner's Manual p. 4.1	•				
<i>Hull damage</i>	Check for loose, damaged or missing parts		Always after striking object				
<i>Stern drive</i>							
Stern Drive							
<i>Fluid level</i>	Check level	Engine Manual	•				
<i>Fluid</i>	Replace	Engine Manual					•
Topside & Supplies	Check for loose, damaged or missing parts	Owner's Manual p. 8.4					•
Transmission							
<i>Oil Strainer Screen</i>	Clean		To be done by Sea Ray dealer annually				
Trim Tabs							
<i>Fluid</i>	Check and add as needed	Trim Tab Manual		•			
Zincs (Also see **Mercathode System)							
<i>Stern drive</i>	Check and replace needed	Owner's Manual p. 6.6	Every 25 hours of operation				
<i>Trim Tabs</i>	Check fluid level	Owner's Manual p. 6.6	Every 25 hours of operation				

*Use in salt water or other severe operating conditions requires shorter maintenance/service intervals

**May not be on your boat



SECTION 8 • REQUIRED INSPECTION, SERVICE AND MAINTENANCE

2. INSPECTION, SERVICE AND MAINTENANCE PROTOCOL

A. BILGE AREA

Many of your boat's systems have critical features located in the bilge area. A thorough and organized inspection of the bilge area will address many of these critical features. For example, engine oil leaks and fuel system leaks will show themselves as contamination on the surface of the liquid that remains in the bilge. When you see such contamination, you should look for its source.

Once or twice a year, pump the bilge areas dry and remove all loose dirt. Be sure that all the limber holes are open. Limber holes are the openings in the stringers that allow water to flow from the outboard areas of the bilge to the bilge sump.

Check the bilge pump float switch by moving it manually. (Figure 4.1.2) The bilge pump should start when the float switch is raised and should stop when lowered. If it does not, have it replaced before using your boat. The float switch should also move freely without sticking, if it does not, have it serviced or replaced before boating.

WARNING

DO NOT USE FLAMMABLE SOLVENTS to clean any part of the bilge.

Fumes can accumulate and can be the source of an explosion.

1. OIL

If there is oil contamination, look for leaks in engine oil lines and engine gaskets. If parts of the bilge have been stained by oil, the stain can be removed using a bilge cleaner available from your dealer or a marine store.

2. ENGINE

Engine failure or malfunction, when away from shore, can be dangerous. Make certain you do the

following each time you use the boat:

- Wipe off the engine to remove accumulated dust, grease and oil.
- Check all exposed nuts, bolts and screws for tightness.
- Inspect the belts for wear. If they do not require replacement, check and adjust the belt tension according to the engine manufacturer's recommendation.
- Inspect engine wiring, and clean and tighten the terminals on the engine electrical system.
- Clean and lubricate the battery cables.
- Add distilled water to the battery cells as needed.
- Refer to your Engine Operator's Manual for additional engine maintenance requirements.

3. FUEL SYSTEM

- Inspect the entire fuel system for evidence of leakage, including the fuel tank fill lines and vents. Any stain around a joint could be an indication of a leak.
- Test all fittings with a wrench to be sure they are not loose, but do not forcefully overtighten the fittings.
- Clean fuel filters and vent screens.

4. WIRING SYSTEM

WARNING

Work on electrical wiring can create shock hazards or sparks.

Always shut off battery switch, breakers and/or pull fuses before checking electrical wiring or connectors.

- Check all wiring for proper support.
- Check all wiring insulation for signs of fraying or chafing.



SECTION 8 • REQUIRED INSPECTION, SERVICE AND MAINTENANCE

- Check all terminals for corrosion - corroded terminals and connectors should be replaced or thoroughly cleaned.
- Tighten all terminals securely and spray them with light marine preservative oil.

5. FITTINGS, HOSES AND CLAMPS

- Inspect the entire bilge area for evidence of damage or deterioration. Evidence of deterioration will first appear around hull fittings, hoses and clamps.
- Straighten kinked hoses.
- Replace any hose that does not feel pliable.
- Check all hose clamps for tightness and corrosion. Corroded clamps must be replaced.
- Check the nuts, bolts and screws that retain equipment, hoses, etc. in the bilge for tightness and corrosion. Corroded fasteners must be replaced.

B. TOPSIDE AND SUPPLIES

Once a year, you should undertake a thorough review of the topside equipment, as well as of the critical safety supplies on your boat.

- Check cleats, rings, rails, etc. for loose or corroded fasteners, breaks, sharp edges or other conditions that could lead to malfunction or unsafe use. Repair or replace as necessary.
- Inspect PFDs (life jackets) for tears and deterioration.
- Make certain you have enough PFDs on board for the maximum number of persons you can carry.
- Check your first aid kit, making certain it is complete and that the items in it have not passed an expiration date.
- Check the signaling equipment and emergency flares. Make sure all items are within their expiration dates.

- Inspect the anchor, mooring and towing lines. Repair or replace as required.
- Check fire extinguishers for full charge.

3. WINTERIZATION CHECKLIST FOR BOATS STORED ON LAND

A. BOAT STORAGE

- Store boat in a bow high attitude.
- Remove hull drain plug.
- Pour one (1) pint (half-liter) of 50% water/antifreeze mixture in each bilge pump sump..

B. ENGINE

- Flush engines with fresh water.
- Remove engine drain plugs.

REFER TO YOUR ENGINE OPERATOR'S MANUAL FOR DETAILED INFORMATION ON PREPARING THE ENGINES FOR STORAGE AND WINTERIZATION.

C. BATTERY(IES)

- Remove from boat. Remove the negative (-) cable first, then the positive (+) cable.
- Remove grease and dirt from top surface.
- Grease terminal bolts.
- Store on wooden pallet or thick plastic in a cool dry place. Do not store on concrete.
- Keep under a trickle charge.
- When placing battery back into service, remove excess grease from terminals, recharge as necessary and reinstall in boat.

D. FUEL SYSTEMS

GASOLINE:

- Fill fuel tank with gasoline and the



SECTION 8 • REQUIRED INSPECTION, SERVICE AND MAINTENANCE

recommended amount of stabilizer and conditioner such as “Stabil®”.

- Run engine(s) for ten minutes to ensure that all gasoline in the carburetor and fuel lines are treated.



CAUTION

Do not overfill. Filling a tank until the fuel flows from vents is dangerous. Allow room for expansion.

DETAILED WINTERIZING, OPERATING INSTRUCTIONS AND WARRANTY INFORMATION ARE PROVIDED BY THE EQUIPMENT MANUFACTURER AND CAN BE FOUND IN THE OWNER'S PACKET.

4. FITTING OUT AFTER STORAGE

A. FUEL SYSTEM

Check the entire fuel system for loose connections, worn hoses, leaks, etc. and repair. This is a primary safety precaution.

Check fuel lines for damage and make sure that they do not come in contact with any moving parts.

B. BATTERY (IES)

Before installing the batteries, clean the terminal posts with a wire brush or steel wool and then attach the cables. After the cable clamps are tightened, smear the post and clamps with vaseline or grease to exclude air and acid. Do not apply grease before attaching and tightening the terminal clamps. Examine all wiring.

C. MISCELLANEOUS

- Check all thru-hull fittings for unobstructed water passage. Be alert for any deteriorated hoses and/or fittings below the water line which
- Test the navigation lights.
- Check all wiring for loose connections.
- Check all switches and equipment for proper operation.

- Check bilge blowers for proper operation. Turn ON blowers and place hand over hull blower vent to make sure air is coming from vent.
- Anchor lines and gear should be inspected and replaced if necessary.
- Make sure the hull drain plug is in place and tight.
- Clean bilge thoroughly if it was not done at lay-up.
- Check all engine fluid levels.
- Check fuel lines for damage and/or leaks. Make sure that they do not come into contact with moving parts.

5. SECURITY CONSIDERATIONS

Be conscious of the security of your boat. Always remove the keys from the ignition, lock hatches, lock the cabin door, remove and stow any removable electronic gear (fishfinders, LORAN, etc.) and personal gear (fishing poles, etc.) normally left aboard your boat.

6. POWER STEERING SYSTEM MAINTENANCE

- Lubricate the control valve on the power steering cylinder through the grease fitting with multipurpose lubricant until grease appears around the rubber boot.
- Coat power assist steering output shaft and exposed steering cable end with appropriate lubricant.
- Lubricate cable end guide pivot point with SAE 30W engine oil.
- Check power steering fluid level in the power steering pump reservoir.
- Inspect all hydraulic hoses for leaks. Keep hoses from rubbing on moving parts and from contact with hot engine parts.



SECTION 8 • REQUIRED INSPECTION, SERVICE AND MAINTENANCE

- Check all fittings, clamps and bolts for tightness every month.
- Check power steering pump drive belt for wear and proper tension every month. Do not overtighten belt. This can cause bearing failure.

REFER TO THE ENGINE OPERATOR'S MANUAL FOR PROPER FLUID LEVELS AND LUBRICANTS.

Sea Ray® recommends that all repairs and/or replacements to steering systems be made by qualified dealers authorized by manufacturer of the steering system of your boat.

DETAILED OPERATING INSTRUCTIONS AND WARRANTY INFORMATION ARE PROVIDED BY THE EQUIPMENT MANUFACTURER AND CAN BE FOUND IN THE OWNER'S PACKET.

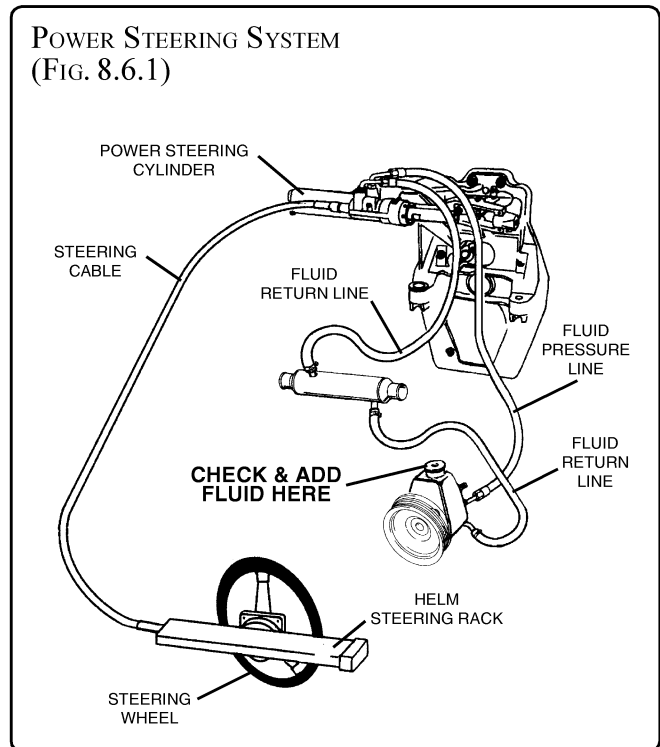

SECTION 9 • CARE & REFINISHING

Your new boat has been designed to provide you with years of enjoyment and satisfaction. In order to maintain the factory new appearance of your boat, we recommend the use of 3M™ Marine's one step Maintenance and Reconditioning Products designed specifically for pleasure boats. Following proper fiberglass maintenance guidelines will help maintain your boat's performance, value, and enjoyment.

1. PAINT CLEANING AGENTS & OTHER SUBSTANCES

WARNING

EXPLOSION/FIRE HAZARD

Care and refinishing materials may contain ingredients that are flammable or explosive. Do not use such materials in the bilge

Shut off electrical power and ventilate when using such materials anywhere on the boat or in the cabin.

Do not create sparks or use lighted materials.

Do not use products containing chlorine, phosphates, perfumes and non-degradable ingredients. Consult your marine dealer regarding environmental regulations before painting the hull. Fumes can last for hours, and chemical ingredients can harm people, property and the environment. Common household cleaning agents may cause hazardous reactions. Read and understand directions on all paint, cleaning and polishing materials before using.

2. FIBERGLASS & GELCOAT

The fiberglass hull, deck and some interior parts consist of a molded shell and exterior gelcoat. The gelcoat is the outer surface, often colored, that presents the shiny smooth appearance associated with fiberglass products. This gelcoat surface is painted or taped in some areas for styling purposes.

Wash the gelcoat and fiberglass regularly with clean, fresh water. Wax gelcoated surfaces to

maintain the luster. In northern climates, a waxing at the start and end of the boating season may suffice. In southern climates, an application of wax every three months will be required for adequate protection.

WARNING

Gelcoat surfaces are slippery when wet.

Always wear non-slip footwear securely fastened to your feet and hold on to rails or the boat structure.

WARNING

Waxed surfaces are slippery.

Do not wax areas that are usually walked on.

REFER TO THE "3M® ONE STEP MAINTENANCE AND RECONDITIONING PRODUCTS" PAMPHLET IN YOUR OWNER'S MANUAL PACKET FOR INSTRUCTIONS AND WARRANTY INFORMATION.

3. STAINS & SCRATCHES

Although gelcoat and painted surfaces are resistant to deep stains, a need for cleaning will occasionally arise. But, the use of some common cleaning agents will permanently discolor or otherwise damage the finish on your boat.

- Do not use abrasive porcelain-cleaning powders. These are too abrasive and contain chlorine and ammonia, either of which will permanently discolor gelcoat and paint.
- Never use nail polish remover (acetone) or any ketone solvents.
- Use diluted household detergents to remove surface soil and stains. Before using a given brand, check to make sure it contains no chlorine or ammonia.
- Alcohol can be used to remove difficult stains. But it must be promptly washed off with mild detergent and water.
- Minor scratches and deeper stains that do not penetrate the gelcoat may be removed by light sanding and buffing.



SECTION 9 • CARE & REFINISHING

4. PERMANENTLY MOORED OR DOCKED BOATS

If permanently moored in salt water or fresh water, your boat will collect marine growth on its bottom. This will detract from the boat's beauty and greatly affect its performance. There are two methods of preventing this:

- Periodically haul the boat out of the water and scrub the bottom with a bristle brush and a solution of soap and water.
- Paint the hull below the waterline with a good grade of antifouling paint. **DO NOT paint the engine drive surfaces.**

NOTE: There are EPA regulations regarding bottom paint application. Consult your Sea Ray® dealer for proper application methods.

5. CARE FOR BOTTOM PAINT

From time to time a slight algae or slime forms on all vessels. The bottom painted portion of the hull can be wiped off with a coarse turkish towel or a piece of old rug while the boat is in the water. Do not use a stiff or abrasive material to clean the bottom paint.

The bottom paint should be inspected annually. If it needs repainting consult your Sea Ray® dealer.

6. TOPSIDE AREAS

A. STAINLESS STEEL AND ALLOY FITTINGS

Stainless steel and alloy fittings should be cleaned with soap and water or household glass cleaner. Remove rust spots as soon as possible with a brass, silver or chrome cleaner. Irreversible pitting will develop under rust that remains for any period of time. Never use an abrasive like sandpaper or steel wool on stainless. These may actually cause rust. To help protect the stainless, we recommend the use of a good car wax.

B. SALT CRYSTALS

When instruments are exposed to a saltwater environment, salt crystals may form on the bezel and the plastic covers. These salt crystals should be removed with a soft, damp cloth; never use abrasives or rough, dirty cloths to wipe plastic parts. Mild household detergents or plastic cleaners can be used to keep the instruments bright and clean.

REFER TO THE OWNER'S MANUAL PACKET FOR INSTRUCTIONS AND WARRANTY INFORMATION.

7. ACRYLIC PLASTIC SHEETING (PLASTIC GLASS)

Never use a dry cloth or duster or glass cleaning solutions on acrylic.

To clean acrylic, first flood it with water to wash off as much dirt as possible. Next, use your bare hand, with plenty of water, to feel and dislodge any caked dirt or mud. A soft, grit-free cloth may then be used with a nonabrasive soap or detergent. A soft sponge, kept clean for this purpose, is excellent. Blot dry with a clean damp chamois.

Grease and oil may be removed from acrylic with kerosene, hexane, white (not aviation or ethyl) gasoline or aliphatic naphtha (no aromatic content).

Do not use solvents such as acetone, silicone spray, benzine, carbon tetrachloride, fire extinguisher fluid, dry cleaning fluid or lacquer thinner on acrylic, since they attack the surface.

Remove fine scratches with fine automotive acrylic rubbing and polishing compounds.

8. CANVAS AND CLEAR VINYL

Do not fold or store any of the canvas pieces while wet. All canvas should be rolled or folded when dry and stored in a clean, dry place. For clear vinyl pieces, the recommended methods for storage are rolling or laying down flat. The clear vinyl should never be folded or



SECTION 9 • CARE & REFINISHING

creased as cracking will result. To protect the clear vinyl from rubbing against itself while rolled or stored flat, place a piece of very soft, nonabrasive cloth between the pieces. If the surface of the clear vinyl becomes scratched, the canvas manufacturer has provided a canvas care sheet located in your Owner's Manual Packet. When storing the rear (aft) curtain, fold the canvas over the clear vinyl window (do not fold clear vinyl), then roll or store flat.

The fabric should be cleaned regularly before substances such as dirt, pollen, etc. are allowed to accumulate on and become embedded in the fabric. The fabric can be cleaned without being removed from the installation. Simply brush off any loose dirt, particles, etc.; hose down and clean with a mild solution of a natural soap in lukewarm water (no more than 100°F, 38°C); rinse thoroughly to remove soap. **DO NOT USE DETERGENTS.** Allow to completely dry.

Wash and clean vinyl windows with a warm soap solution. Use a soft cloth or sponge and do not scratch the surface.

If you have stubborn cleaning cases, call your dealer for proper procedures. Do not try your own cleaning procedures as they may permanently damage the canvas.

After each use, especially in salt water areas, rinse the canvas completely with fresh cold water. Then let the canvas dry completely before stowing.

All metal components of the canvas should be rinsed with fresh cold water and exposed components wiped dry to maintain appearance and working order.

9. EXTERIOR UPHOLSTERY FABRIC

Exterior fabrics should be cleaned with a sponge or very soft scrub brush and a mild soap and warm water solution. After scrubbing, rinse with plenty of cold, clean water and allow the fabric to air dry in a well ventilated place, preferably away from direct sunlight.

Mildew can occur if your boat does not have adequate ventilation. Heat alone will not prevent mildew; you must also provide for fresh air circulation.

REFER TO THE OWNER'S MANUAL PACKET FOR INSTRUCTIONS AND WARRANTY INFORMATION.



SECTION 9 • CARE & REFINISHING

THIS PAGE LEFT INTENTIONALLY BLANK

