

Sea Ray

Owner's Manual

240 Sundeck



Manual Part Number: MRP 2113713

WELCOME

Congratulations on becoming the new owner of a Sea Ray® Boat, the world's most prestigious manufacturer of boats. We welcome you into our worldwide and ever-expanding family of boating enthusiasts.

This Owner's Information Packet will provide important information about features of your boat and should be kept on board your Sea Ray®.

For years of trouble-free boating, take the time to carefully review the information in this package and really get to know your boat. **Have everyone who will operate your boat read the Owner's Manual.**

The Owner's Information Packet contains the following:

- **Sea Ray® Owner's Manual**

The Sea Ray Owner's Manual contains important operating and safety information, as well as reminding you about your responsibilities as a boat owner/operator.

- **Model Specific Owner's Manual**

The Model Specific manual contains information specific to your model.

- **Original Equipment Manufacturer (OEM) Information**

The OEM Information of your Owner's Information Packet contains information provided by the individual systems manufacturers of equipment installed on your boat. Examples include the engine, engine control and electronics equipment. Throughout the Owner's Manual you will be referred to information provided by manufacturers of specific systems.

For a complete library of all Sea Ray manuals including owners, systems, accessories, and options please visit www.searay.com. There you will be able to view all Sea Ray manuals and any items that are not included in this manual.

Because your purchase represents a substantial investment, we know you will want to take the necessary measures to protect its value. We have outlined a program for proper operation, periodic maintenance and safety inspections. We urge you to follow these recommendations. If you have questions which are not fully covered by the Owner's Information Package, please consult your authorized Sea Ray® Boats dealer for assistance.

Thank You For Selecting A Sea Ray®!
Bon Voyage

Sea Ray®



Information in this publication is based upon the latest product specifications available at printing. Sea Ray® Boats, Inc. reserves the right to make changes at any time, without notice, in the colors, equipment, specifications, materials and prices of all models, or to discontinue models. Should changes in production models be made, Sea Ray® is not obligated to make similar changes or modifications to models sold prior to the date of such changes.

Printed in the U.S.A. April 2013
© Sea Ray Boats, Inc. • A Brunswick Company

Sea Ray Boats, Inc. 2600 Sea Ray Blvd., Knoxville, TN 37914
Please visit www.searay.com for a complete library of all Sea Ray Owner's and Accessory Manuals.

Note: Not all accessories shown in pictures or described herein are standard equipment or even available as options.
Options and features are subject to change without notice.

The following are registered trademarks of the Brunswick Corporation: Sea Ray® & The SR Wave Logo

Sea Ray ®



TABLE OF CONTENTS

INTRODUCTION v

1. This Manual	v
2. Your Responsibilities	v
3. Safety/Warning References	v
4. Sources of Information.....	vi
5. Dealer Responsibilities	vi
6. Warranties.....	vi
7. Hull Identification Number (HIN)	vi
8. Manufacturer's Certification	vi
9. Prep, Service, Parts and Repair for Your Boat	vii
10. International Requirements	vii
11. Warranty Information.....	vii

240 SUNDECK OWNERS MANUAL 1

1. Passenger Locations/Stability.....	1
2. Load Capacity.....	2
3. Design Category	4
4. Safety Label Locations	5
5. Key to Symbols on Controls and Prints	7
6. Basic Boat Dimensions and Clearances	8
7. Function and Location of Through-Hull Cutouts	9
8. Helm, Instrument & Switch Layout.....	10
9. Deck Layout.....	12
10. Cleats/Lifting/Storage	13
11. Navigation and Anchor Lights	14
12. Bilge.....	15
13. Engines.....	16
14. Fuel System.....	16
15. Water System	20
16. Automatic Fire Extinguisher System.....	21
17. Entertainment System	22
18. Canvas.....	22

240 SUNDECK ELECTRICAL SYSTEM 23

1. Batteries.....	23
2. Ignition Protection.....	25
3. Battery Switch.....	26
4. Battery Selector Switch	26
5. DC Power Distribution.....	27
6. Fuses and Breakers.....	27
7. Permanently Installed Pre-wired Battery Charger	28
8. Electrical Schematics.....	28

INDEX I

This publication does not contain component or accessory manuals.
Please visit www.searay.com for a complete library of all Sea Ray
Owner's and Accessory Manuals



THIS PAGE INTENTIONALLY LEFT BLANK

INTRODUCTION

1. THIS MANUAL

The material here and in the rest of the Owner's Information Packet:

- Gives you basic safety information;
- Describes the fundamentals of boat use;
- Describes the features of your boat;
- Describes the equipment on your boat;
- Contains service and maintenance information.

You must learn to safely operate this boat as well as read, understand and use the information contained in this package.

What these manuals do not give you is a course in boating safety, or how to navigate, anchor, or dock your boat. Operating a power boat safely requires more skills, knowledge, and awareness than is necessary for a car or truck.

2. YOUR RESPONSIBILITIES

For your safety, the safety of your passengers, other boaters and people in the water, you must:

- Take a boating safety course;
- Get instruction in the safe and proper handling of your boat;
- Understand and follow the "Rules of the Road";
- Learn how to navigate;
- Register:

You must register this boat in the state where it will be used most frequently, many states require additional registration when an out-of-state boat is used within their boundaries.

Contact state boating authorities or any marine dealer for registration requirements.

3. SAFETY/WARNING REFERENCES

EXPLANATION OF SAFETY/WARNING REFERENCES

The most important aspect of boating is safety. Although every effort is made to address the numerous issues regarding the safe usage of your boat, it is strongly recommended that you avail yourself to the training and knowledge available through boating safety courses, etc.

SAFETY PRECAUTIONS

The precautions below appear throughout this manual and are mounted at key locations throughout your boat. These precautions must be observed when operating or servicing your boat. Learn to recognize the degree of precaution and understand the explanations of safety prior to reading this manual. These precautions are not all-inclusive. Always use common sense in the operation of your boat.

- Do not remove or obstruct any safety label.
- Replace any label which becomes illegible. Replacement safety labels can be obtained by calling your dealer.

DANGER

DANGER - Immediate hazards which WILL result in severe personal injury or death if the warning is ignored.

WARNING

WARNING - Hazards or unsafe practices which MAY result in severe personal injury or death if the warning is ignored.

CAUTION

CAUTION - Hazards or unsafe practices which could result in minor injury, product or property damage if the warning is ignored.

NOTICE

Information which is important to proper operation or maintenance, but is not hazard related.



INTRODUCTION

4. SOURCES OF INFORMATION

In North America, contact one of the following for boating courses:

- U.S. Coast Guard Auxiliary
- U.S. Power Squadron
- Canadian Power and Sail Squadrons
- Red Cross
- State Boating Offices
- Yacht Club

Contact your dealer or the Boat/U.S. Foundation at:

1-800-336-2628

Outside of North America, contact your boat dealer and/or your governmental boating agency for assistance.

A book that provides a comprehensive background in boating is **Chapman - Piloting, Seamanship and Small Boat Handling**, by Elbert S. Maloney, published by Hearst Marine.

5. DEALER RESPONSIBILITIES

In addition to a pre-delivery check and service of the boat, your dealer is to give you:

- A description and demonstration of the safety systems, features, instruments and controls on your boat;
- An orientation in the general operation of your boat;
- An “In Service Check List” form completed by you and the dealer after your inspection of the boat;
- A review of all warranty information and how to obtain warranty service;
- The Owner Information Package.

If you do not receive all of these materials, or have any questions, contact your dealer.

6. WARRANTIES

Your boat comes with several warranties. Each component and/or system on your boat has its own warranty that will be found with the specific information and manual for that component. These are included with your Owner’s Manual Packet. The Sea Ray® Express Limited Warranty is on the warranty information sheet and in this manual. Please locate and read the individual warranties.

7. HULL IDENTIFICATION NUMBER (HIN)

The “Hull Identification Number”, (Fig. vi.1) will be located either on the starboard side of the transom, or on the aft, starboard side of the gunwale, and is your boat’s most important identifying factor. This number must be included in all correspondence and orders. Failure to include it creates delays. Also of vital importance is the engine serial number and part number when writing about or ordering parts for your engine. Refer to the Engine Operator’s Manual for location of engine serial number and record it for future reference.

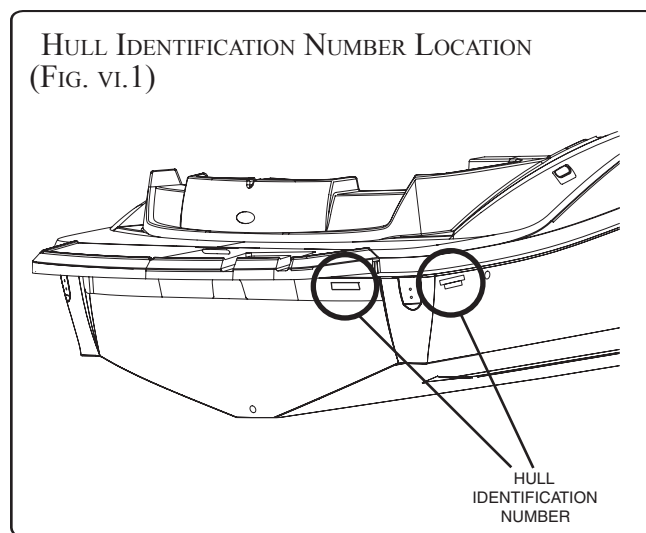

8. MANUFACTURER’S CERTIFICATION

As a boat manufacturer, Sea Ray® builds their products to guidelines established under the Federal Boat Safety Act of 1971. The Act is promulgated by the United States Coast Guard who has authority to enforce these laws on boat manufacturers that sell

INTRODUCTION

products in the United States. Sea Ray® ensures that all of its products comply with these laws.

The National Marine Manufacturers Association (NMMA) provides Sea Ray® with a third party certification. The NMMA is an organization that represents the marine industry and assists manufacturers, boat dealers, marinas, repair yards and component suppliers in areas of legislation, environmental concerns, marine business growth and state and federal government agency interaction. The third party certification that Sea Ray® participates in, uses the well known Standards and Recommended Practices of the American Boat and Yacht Council (ABYC).

Sea Ray® Boats participates extensively in the American Boat and Yacht Council which is a nonprofit organization that develops and publishes voluntary standards and recommended practices for boat and equipment design, construction, service and repair. We utilize all applicable ABYC standards in the construction of your Sea Ray® boat.

Finally, Sea Ray® sells their products world wide and as such must conform to the various rules and regulations required by other countries. Most notably, are the ISO standards in Europe which require the application of the Common European (CE) mark. This mark, much like the NMMA certification here in the US, gives you the boat owner specific information concerning your craft.

9. PREP, SERVICE, PARTS AND REPAIR FOR YOUR BOAT

Sea Ray® advises that all rigging, installation, and prep work on any Sea Ray® product be done by an authorized dealer at the authorized dealer's location.

When your boat needs service, parts or repair, take it to an authorized Sea Ray® dealer. To find a dealer in your area contact Sea Ray® via the internet at www.searay.com (international customers please visit international.searay.com).

To find repair and parts facilities for the equipment installed on your boat, refer to the section or manual for that component.

If a problem is not handled to your satisfaction:

1. Discuss any warranty-related problems directly with the service manager of the dealership or your sales person. Give the dealer an opportunity to help the service department resolve the matter for you.
2. If a problem arises that has not been resolved to your satisfaction by your dealer, contact Sea Ray® via the internet at www.searay.com and the appropriate customer service information will be provided to you.

10. INTERNATIONAL REQUIREMENTS

Depending on your boat's original destination, the vessel and its systems may have been constructed in accordance with standards and specifications published by various international authorities such as:

- Construction Standards for Small Vessels - Canada
- Recreational Craft Directive and applicable ISO Standards - European Union
- AS/NZ 3004 Electrical Installations - Australia/ New Zealand

Further information concerning these requirements may be obtained from your local dealer.

11. WARRANTY INFORMATION

You will find information regarding the Sea Ray® warranty following the introduction. A warranty information card is also included in the owner information packet. If for some reason this information is missing, contact your Sea Ray® dealer.



INTRODUCTION

Sea Ray[®] ABOUT YOUR LIMITED WARRANTY

Sea Ray[®] offers an express Limited Warranty on each new Sea Ray[®] purchased through an authorized Sea Ray[®] dealer. A copy of the Limited Warranty was included in your owner's manual package. If for any reason, you did not receive a copy of the Limited Warranty, please contact your local dealer for a replacement copy. This is a summary of several provisions of the Limited Warranty. Please read the Limited Warranty, which is the controlling document.

Under the Limited Warranty, Sea Ray[®] covers: (a) structural fiberglass deck or hull defects for the lifetime of the original ownership; (b) parts found to be defective in factory material or workmanship within one (1) year of the date of delivery; (c) laminate blisters resulting from defects in factory material or workmanship for five (5) years on a prorated basis.

Sea Ray[®]'s obligation under the Limited Warranty is limited to repair or replacement of parts that are judged defective by Sea Ray[®] and does not include transportation, haul out, or other expenses. The foregoing is the **sole and exclusive** remedy provided by Sea Ray[®].

The Limited Warranty does not cover engines, stern drives, controls, propellers, batteries, trailers, or other equipment or accessories carrying their own individual warranties, nor does the Limited Warranty cover engines, parts or accessories not installed by Sea Ray[®]. The Limited Warranty does not cover cosmetic gel coat finish. Boats used for commercial purpose are excluded from coverage. **See the Sea Ray[®] Limited Warranty for other exclusions.**

SEA RAY[®] EXPRESSLY DISCLAIMS THE IMPLIED WARRANTIES OF MERCHANTABILITY AND FITNESS. NEITHER SEA RAY[®] NOR THE SELLING DEALER SHALL HAVE ANY RESPONSIBILITY FOR LOSS OF USE OF THE BOAT, LOSS OF TIME, INCONVENIENCE, COMMERCIAL LOSS OR CONSEQUENTIAL DAMAGES.

The unexpired term of the limited warranty may be transferred to a subsequent owner upon the new owner's request, except this limited warranty will not transfer to any subsequent owner of a boat which has been salvaged or resold after declaration of a total loss or a constructive total loss, i.e., the cost of repair exceeds the value of the boat. The new owner can submit this request, free of charge, via the searay.com website or through a local authorized Sea Ray Dealer where processing fees may be applied. Sea Ray reserves the right to reject any warranty transfer request for a boat that has been damaged, neglected, or otherwise previously excluded from warranty.

Thank you for your decision to buy a Sea Ray[®].

The Sea Ray[®] Limited Warranty is subject to change at any time at Sea Ray's discretion. The information contained herein is general information about the Limited Warranty for the owner's general knowledge, but does not alter or amend the terms of the Limited Warranty.



240 SUNDECK OWNERS MANUAL

1. PASSENGER LOCATIONS/STABILITY

WARNING

Wet decks are slippery.
You can be seriously injured if you slip and fall.
Wear slip resistant footwear secured to your feet and hold on to rails or boat structure.

WARNING

Boat motion can be erratic.
You can fall overboard or be injured by hitting something in or on the boat.
All persons must be in cockpit area or cabin and be prepared for sudden boat movement.
Use front or bow deck area only during anchoring, mooring or emergencies.

When persons are on the working deck area, for anchoring, mooring, or in emergencies, they must be holding on and be positioned so as to prevent falling. In bad weather and/or rough water, if it is essential to be on deck, persons should be closely tied to cleats, railing stanchions or other securely fastened boat hardware.

Your boat was manufactured to specific stability and flotation standards for the capacity shown on the certification plate. Any increase from the recommended load capacities will put your boat in jeopardy of capsizing, swamping and/or sinking.



In Addition:

- Stability may be substantially reduced if equipment is added above the deck.
- Stability is substantially reduced by loose fluids or weight within the hull. Keep bilge area as dry as possible, and close all openings, hatches and windows in rough weather.

WARNING

Distribute passengers and gear as uniformly as possible from front to rear and left to right.
The manufacturer's load rating is the maximum allowed under calm conditions.
Reduce boat loading if weather, water or other conditions are adverse.

PASSENGER LOCATIONS (FIG. 1.1)

-  ACCOMMODATION DECK
(DECK AREA INTENDED FOR OCCUPATION DURING NORMAL OPERATION)
-  WORKING DECK
(DECK AREA INTENDED FOR OCCUPATION DURING ANCHORING, MOORING AND EMERGENCY OPERATION ONLY)
-  DO NOT WALK ON THIS AREA

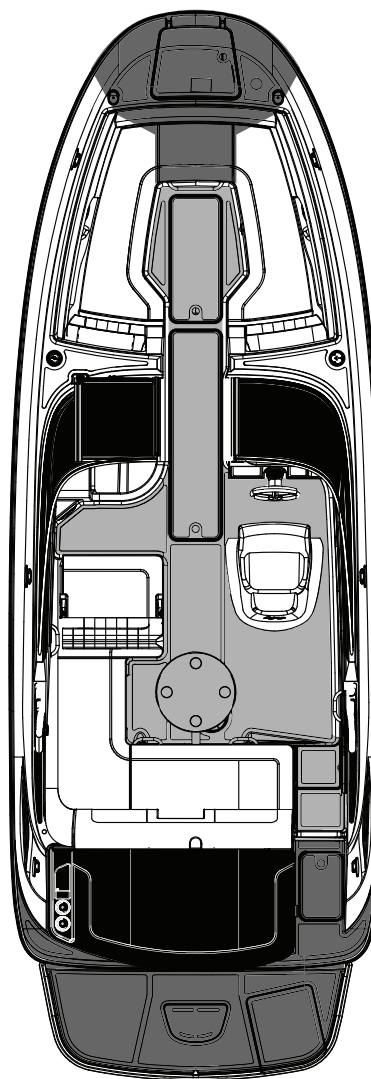

DANGER

Rotating propellers can injure or kill you.

Shut off engine when persons are in water near boat, or on swim platform or ladder.

WARNING

Rear facing transom seats **MUST NOT** be used while engine is running or boat is moving.



240 SUNDECK OWNERS MANUAL

2. LOAD CAPACITY

⚠ DANGER

Never carry more weight or passengers than indicated on the certification plate, regardless of weather or water conditions.

The boat can capsize, swamp or sink.

If present the capacity information plate, located near the helm indicates maximum weight and number of persons your boat can handle under calm sea conditions. Do not exceed the load capacities stated. The number of people on board must be reduced if you go out in poor weather and rough water.

CAPACITY PLATE (DOMESTIC CERTIFICATION)
(FIG. 2.1)

MAXIMUM NUMBER OF PASSENGERS

MAXIMUM LOAD CAPACITY

MAXIMUM CAPACITIES

13 PERSONS OR 1773 LBS.
-1923 POUNDS, PERSONS, GEAR

THIS BOAT COMPLIES WITH U.S. COAST GUARD SAFETY STANDARDS IN EFFECT ON THE DATE OF CERTIFICATION

MANUFACTURER: SEA RAY BOATS, INC., KNOXVILLE, TN.

MODEL: 240SD

DESIGN COMPLIANCE WITH NMMA REQUIREMENTS BELOW IS VERIFIED. MFR. RESPONSIBLE FOR PRODUCTION CONTROL

LOAD AND CAPACITY • COMPARTMENT VENTILATION STEERING, FUEL AND ELECTRICAL SYSTEMS

INTERNATIONAL LIGHTS • BASIC FLOTATION MANEUVERABILITY

NATIONAL MARINE MANUFACTURERS ASSN.

CAPACITY PLATE (INTERNATIONAL CERTIFICATION)
(FIG. 2.2)

Sea Ray Boats

MAXIMUM

10' + 3 = 872 kg

DESIGN CATEGORY

MAXIMUM NUMBER OF PASSENGERS

MAXIMUM LOAD CAPACITY

The type of capacity plate will vary dependant upon the local governing authority.

- A. United States – The United States Coast Guard only provides specific numbers for passenger capacity or cargo weight for recreational vessels up to 20', (6.1 meters). NMMA provides capacity for boats under 26' (7.9 meters).
- B. Canada – Transport Canada only provides specific numbers for passenger capacity or cargo weight for recreational vessels up to 6 meters (19.7').
- C. Australia – The Australian Transport Council provides specific numbers for passenger capacity and cargo weight for all recreational vessels.
- D. European Union – CE regulations provide specific information for passenger capacity and cargo weight for all recreational vessels.



240 SUNDECK OWNERS MANUAL

PASSENGER LOCATIONS
(FIG. 3.1)

NOTICE

The maximum number of persons listed on the capacity plate may be affected by where the vessel is registered. Refer to Section 2 for further information.

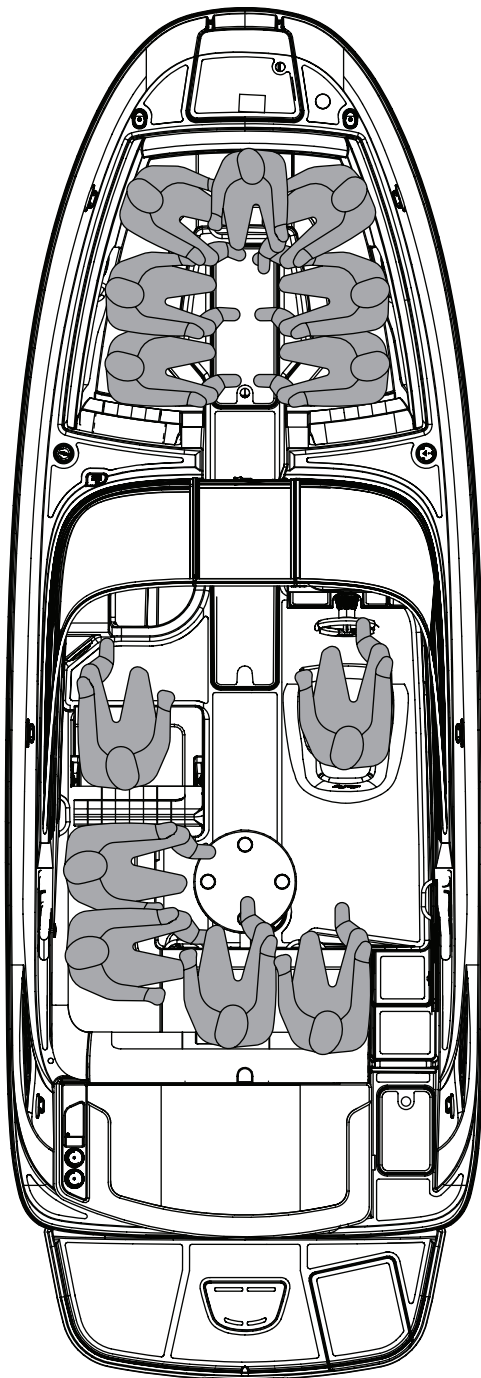

DOMESTIC

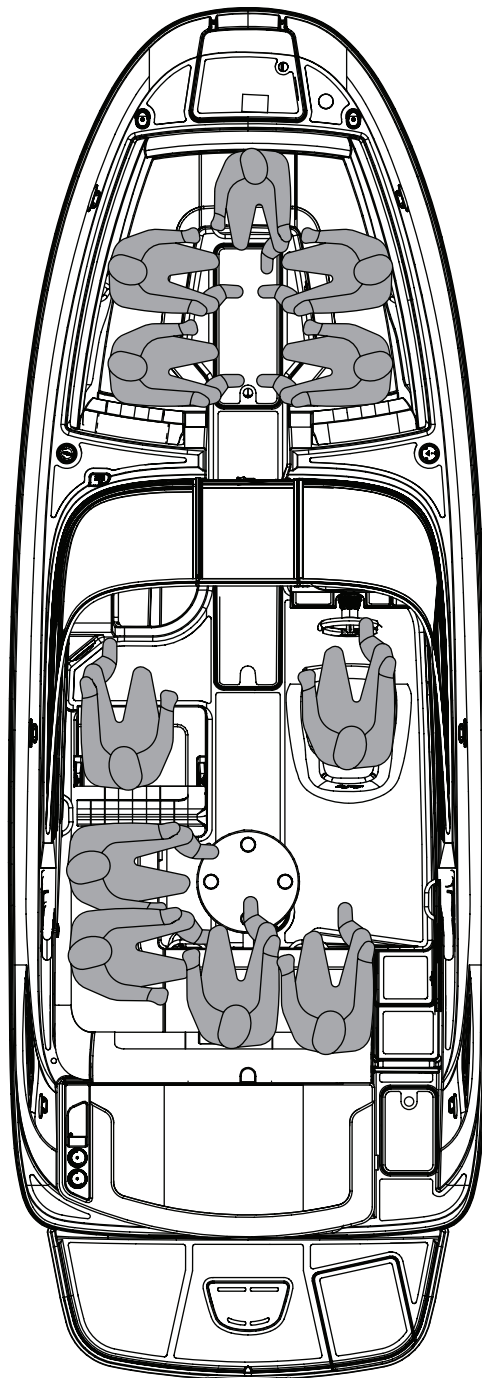

EUROPEAN, (CE)



3. DESIGN CATEGORY

There are four design categories of boats based upon their ability to withstand wind and sea or water conditions:

A. Ocean

Wind speed: above 40 knots (46 mph)
Wave height: above 4 meters (13 feet)
Boat may be used for extended ocean voyages.

B. Offshore

Maximum wind speed: 40 knots (46 mph)
Maximum wave height: 4 meters (13 feet)
Boat can be used offshore, but not for extended ocean voyages.

C. Inshore

Maximum wind speed: 27 knots (31 mph)
Maximum wave height: 2 meters (6.5 feet)
Boat use is limited to coastal waters, large bays, estuaries, lakes and rivers.

D. Sheltered waters

Maximum wind speed: 15 knots (18 mph)
Maximum wave height: 0.5 meters (1.5 feet)
Boat use is limited to small lakes, rivers and canals.



DANGER

**DO NOT ATTEMPT TO BOAT IN
SEVERE WEATHER CONDITIONS**

DEATH OR SERIOUS INJURY CAN OCCUR

**GET TO SHORE BEFORE
THE WEATHER TURNS BAD**

The wind speed and wave height specified as the upper limit for your category of boat does not mean that you or your passengers can survive if your boat is exposed to these conditions. It is only the most experienced operators and crew that may be able to operate a boat safely under these conditions. You must always be aware of weather conditions and head for port or protected waters in sufficient time to avoid being caught in high winds and rough water. Do not take chances!

240 SUNDECK OWNERS MANUAL

4. SAFETY LABEL LOCATIONS

SAFETY LABEL LOCATIONS
(FIG. 5.1)

WARNING

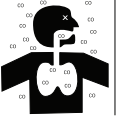

Carbon Monoxide (CO) can cause brain damage or death.

Engine and generator exhaust contains odorless and colorless carbon monoxide gas.

Signs of carbon monoxide poisoning include nausea, headache, dizziness, drowsiness, and lack of consciousness.

Get fresh air if anyone shows signs of carbon monoxide poisoning.

See Owner's manual for information regarding carbon monoxide poisoning.

MAXIMUM CAPACITIES

13 PERSONS OR 1773 LBS.
1923 POUNDS, PERSONS, GEAR

THIS BOAT COMPLIES WITH U.S. COAST GUARD SAFETY STANDARDS IN EFFECT ON THE DATE OF CERTIFICATION

MANUFACTURER: SEA RAY BOATS, INC., KNOXVILLE, TN.

MODEL: 240SD

DESIGN COMPLIANCE WITH NMMA REQUIREMENTS BELOW IS VERIFIED. MFR. RESPONSIBLE FOR PRODUCTION CONTROL

LOAD AND CAPACITY • COMPARTMENT VENTILATION STEERING, FUEL AND ELECTRICAL SYSTEMS
INTERNATIONAL LIGHTS • BASIC FLOTATION MANEUVERABILITY

NATIONAL MARINE MANUFACTURERS ASSN.

MEETS U.S. EPA EVAP STANDARDS USING CERTIFIED COMPONENTS

SEA RAY BOATS, KNOXVILLE, TN.

THE UNITED STATES COAST GUARD (USCG) RECOMMENDS THAT ALL OCCUPANTS WEAR APPROVED PERSONAL FLOTATION DEVICES (PFD'S)

DANGER

PROPELLER(S) MAY CAUSE SERIOUS INJURY OR DEATH

Shut-off engine(s) when near swimmers, prior to using sunpads, swim platform, or boarding ladder.

WARNING

AVOID COLLISIONS

- Maintain lookout as required by the "Rules of the Road"
- Visibility can be limited by high boat trim angles, persons, gear, weather and atmospheric conditions.
- At all times proceed at a safe speed, in order to take proper and effective action to avoid hazardous conditions.

SUCH ISSUES ARE UNDER THE CONTROL OF THE OPERATOR!

AVOID SKI LINES AND TOW ROPES

Ski lines and tow ropes can backlash into the cockpit when released.

CAUTION

AVOID INHALATION OF TOXIC FUMES -

If fire extinguishing system discharging occurs ventilate space before entering.

12VDC-15A MAX

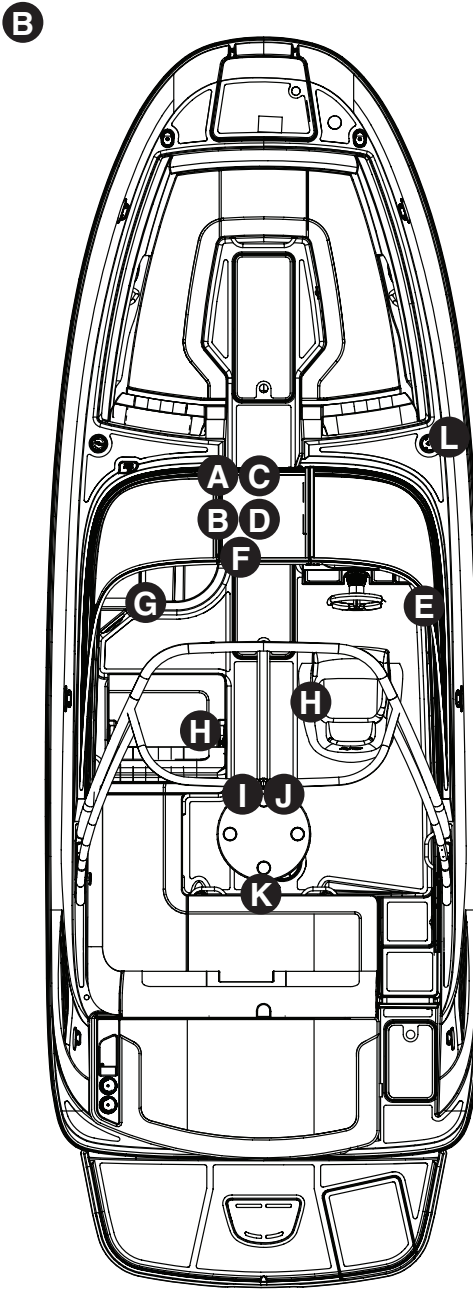

F

CE 0609 C

Sea Ray Boats

MAXIMUM

10 + = 872 kg

CE OPTION ONLY

G

WARNING

DOOR MUST BE SECURED WHILE BOAT IS UNDERWAY

H

WARNING

AVOID SERIOUS OR FATAL INJURY DUE TO ROTATION OF SEAT

LOCK SWIVEL WHEN SPEED EXCEEDS 5 MPH.

I

WARNING

DO NOT EXCEED MAXIMUM TOW WEIGHT OF 600 LBS.

J

WARNING

SUNSHADE SHOULD NOT BE USED AT SPEEDS ABOVE 45 MPH.

K

WARNING

IN CASE OF FIRE, DO NOT OPEN ENGINE BOX OR COMPARTMENT.

SHUT DOWN ENGINES, GENERATORS OR BLOWERS

CONTINUOUSLY DISCHARGE ENTIRE CONTENTS OF HALON OR CO PORTABLE FIRE EXTINGUISHER THROUGH PORT IMMEDIATELY.

L

FRESH WATER



240 SUNDECK OWNERS MANUAL

SAFETY LABEL LOCATIONS (FIG. 6.1)

⚠ DANGER
STAY CLEAR OF MOVING PARTS

A

NOTICE
CHECK BATTERY CELL FLUID LEVEL
APPROXIMATELY EVERY 4 WEEKS AND MORE
OFTEN IN SUMMER AND HOT ZONES.

B

NOTICE
FIXED FIRE EXTINGUISHING SYSTEM MUST
BE SUITABLE FOR GROSS COMPARTMENT
VOLUME OF 100 CU FT.

C

⚠ WARNING
LEAKING FUEL IS A FIRE AND EXPLOSION
HAZARD. INSPECT SYSTEM REGULARLY.
EXAMINE FUEL TANKS FOR LEAKS OR
CORROSION AT LEAST ANNUALLY

D

⚠ CAUTION
IF SWITCH IS TURNED OFF
WHILE ENGINE IS RUNNING
ALTERNATOR WILL BE DAMAGED

E

⚠ WARNING
Gasoline vapors are explosive
Avoid serious injury or death from fire or
explosion resulting from leaking fuel.
Inspect system for leaks at least once a year.

The use of fuels containing ethanol higher than
10% (E-10) can damage your engine or fuel
system and will void the warranty. Never use (E-85).

Open flame appliances can ignite gasoline vapors
causing death or injuries from the fire or explosion.
Turn off all open flame appliances when refueling.

F

PREVENT THE DISCHARGE OF POLLUTANTS
DISCHARGE OF OIL OR OILY WASTE INTO NAVIGABLE WATERS IS
PROHIBITED IF SUCH A DISCHARGE CAUSES A FILM, SHEEN OR
A DISCOLORATION OF THE SURFACE, OR CAUSES A SLUDGE OR
EMULSION BENEATH THE SURFACE OF THE WATER.
VIOLATORS WILL BE SUBJECT TO PENALTIES.

G

⚠ DANGER

Carbon Monoxide (CO) can cause brain damage
or death.
Engine and generator exhaust contains odorless
and colorless carbon monoxide gas.
Carbon monoxide will be around the back of the
boat when engines or generators are running.
Move to fresh air, if you feel nausea, headache,
dizziness or drowsiness.

H

I

⚠ DANGER
TRANSOM DOOR MUST BE
CLOSED AND SECURE WHEN
ENGINE IS RUNNING

J

⚠ WARNING
YOU CAN DIE OR BE SERIOUSLY INJURED BY
BREATHING **CARBON MONOXIDE**
OR BY THE **PROPELLER** IF YOU
FALL OVERBOARD.
REAR FACING TRANSOM SEATS **MUST NOT**
BE USED WHILE ENGINE IS RUNNING OR
BOAT IS MOVING

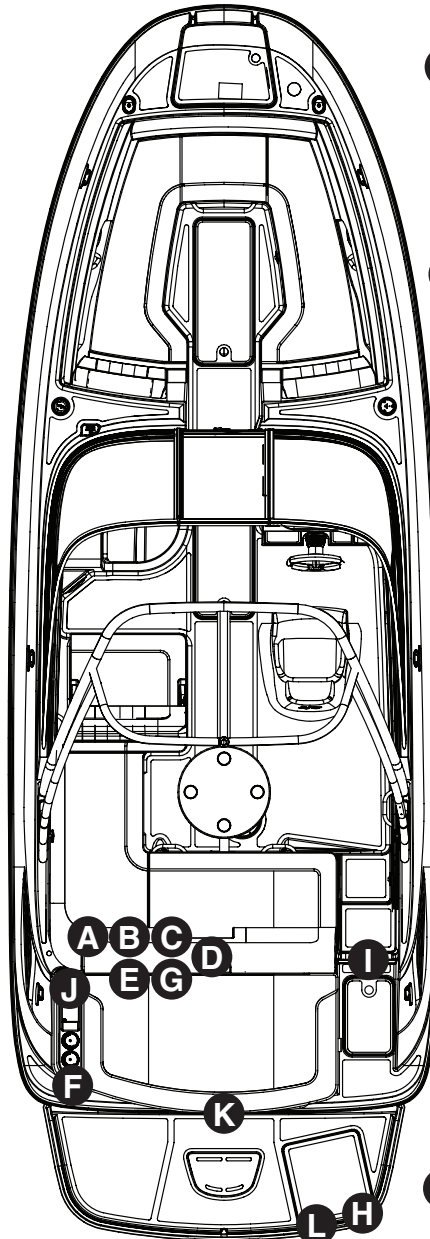

K

⚠ WARNING
USE CAUTION WITH SKIER IN TOW
AS TOW ROPE MAY BACKLASH INTO
COCKPIT WHEN RELEASED.

L















































⚠ DANGER
TO AVOID THE RISK OF SERIOUS INJURY OR DEATH
SHUT OFF ENGINE WHEN NEAR SWIMMERS
OR PRIOR TO USING SWIM PLATFORM AND
BOARDING LADDER.



240 SUNDECK OWNERS MANUAL

5. KEY TO SYMBOLS ON CONTROLS AND PRINTS

These symbols may be found on your controls and gauges and/or used in this owner's manual. This page is to help you understand what the symbols mean.

 EMERGENCY START SWITCH (TWIN ENGINE ONLY)	 ENGINE EXHAUST CONTROL	 ENGINE ROTATIONAL SPEED	 ENGINE COOLANT	 ENGINE (COOLANT) WATER JACKET TEMPERATURE	 ENGINE OIL PRESSURE	 ENGINE
 FUEL GENERAL	 DIESEL FUEL	 FUEL LEVEL	 FUEL FILTER	 LEADED FUEL	 UNLEADED FUEL	 ENGINE START
 BILGE BLOWER	 BILGE PUMP	 OIL	 ELAPSED TIME	 LIGHT	 INTERIOR LIGHT	 ENGINE STOP
 RUNNING LIGHTS UNDER POWER	 ANCHOR LIGHT	 FRESH WATER BASED COOLANT	 WASTE WATER/SEWAGE	 WINDSHIELD WIPER	 WINDSHIELD WASHER	 PROPELLER
 WINDSHIELD WIPER AND WASHER	 COMPASS	 ANCHOR	 HORN	 PROPULSION SYSTEM TRIM	 PROPULSION SYSTEM TRIM BOW UP	 LIFT POINT OR PROPER LOCATION OF SLING
 PROPULSION SYSTEM TRIM BOW DOWN	 TRIM TAB TRIMMING OPERATION	 SINGLE LEVER CONTROL (THROTTLE & SHIFT)	 CONTROL LEVER OPERAT- ING DIRECTION	 ROTARY CONTROL (QUANTITY INCREASES WITH WIDTH OF SYMBOL)	 BATTERY	 LIFT POINT
 WARNING ELECTRICAL HAZARD	 FIRE RISK	 NO OPEN FLAME NO SMOKING	 WATER PUMP	 ACCESSORY		



240 SUNDECK OWNERS MANUAL

6. BASIC BOAT DIMENSIONS AND CLEARANCES

BOAT DIMENSIONS AND CLEARANCES
(FIG. 8.1)

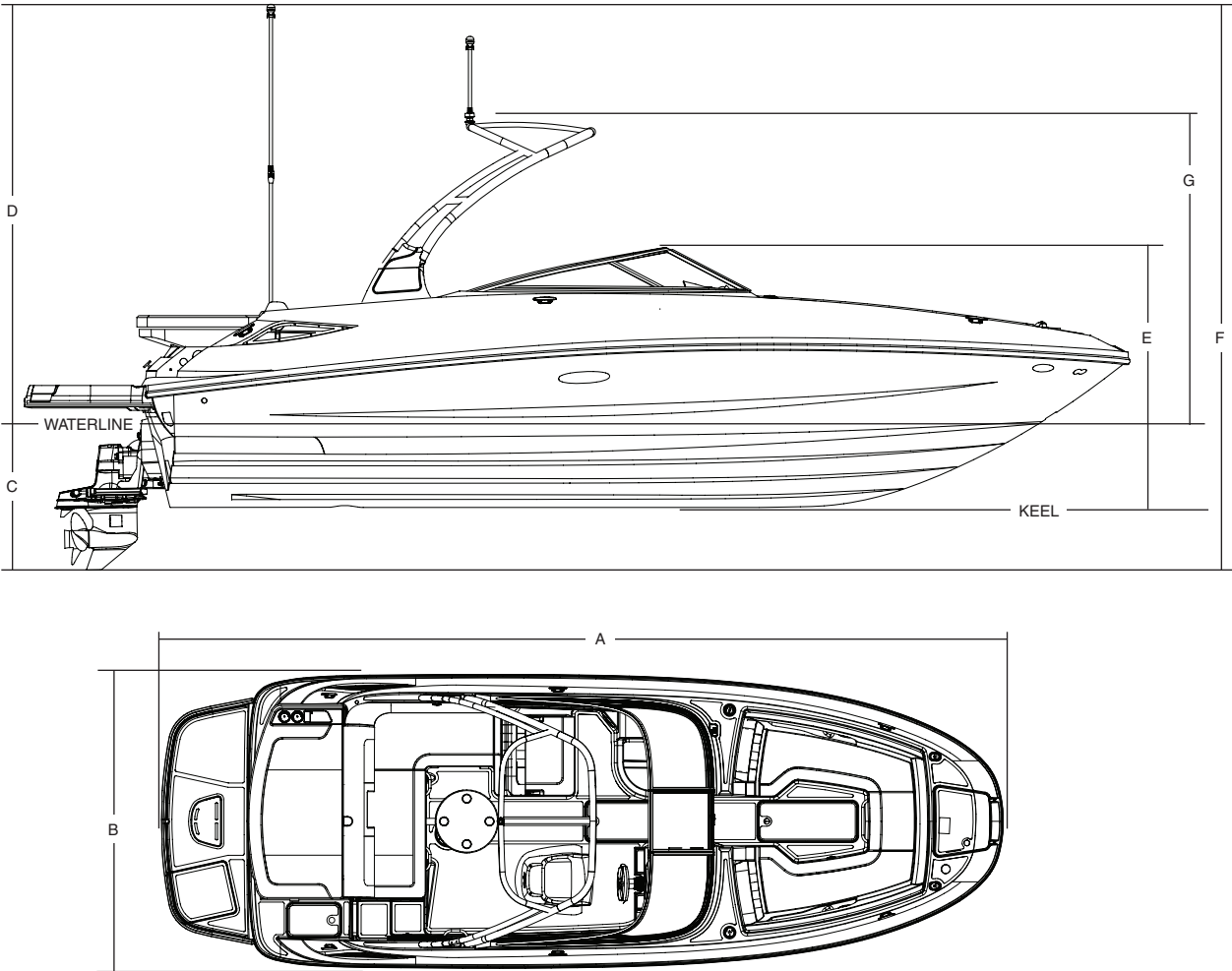

240 SUNDECK® SPECIFICATIONS

(A) Overall Length		
With Opt. Swim Platform	24ft. 6½in.	6.86 m
(B) Beam (Width).....	8ft. 8in.	2.55 m
(C) Draft (Stern Drive Down)	38in.*	96.5 cm*
Draft (Stern Drive Up).....	20in.*	50.8 cm*
* MINIMUM WATER DEPTH TO PREVENT RUNNING AGROUND		
Dry Weight.....	4,616 lbs.	2,094 kg.
Fuel Capacity.....	58 gal.	219 liters
Dead Rise.....	21°	

HEIGHT DIMENSIONS

(D) Overall Height from Waterline.....	9ft. 5½ in.	2.89 m
(E) Keel to Top of Windshield.....	5ft. 9 in.	1.75 m
(F) Overall Height from Stern Drive	11ft. 8¼ in.	3.56 m
(G) Waterline to top of Spoiler.....	6ft. 8 in.	2.03 m

NOTE - DIMENSIONS CAN VARY DEPENDING ON LOAD AND RUNNING CONDITIONS.



240 SUNDECK OWNERS MANUAL

7. FUNCTION AND LOCATION OF THROUGH-HULL CUTOUTS

PORT THROUGH-HULL CUTOUTS
(FIG. 9.1)

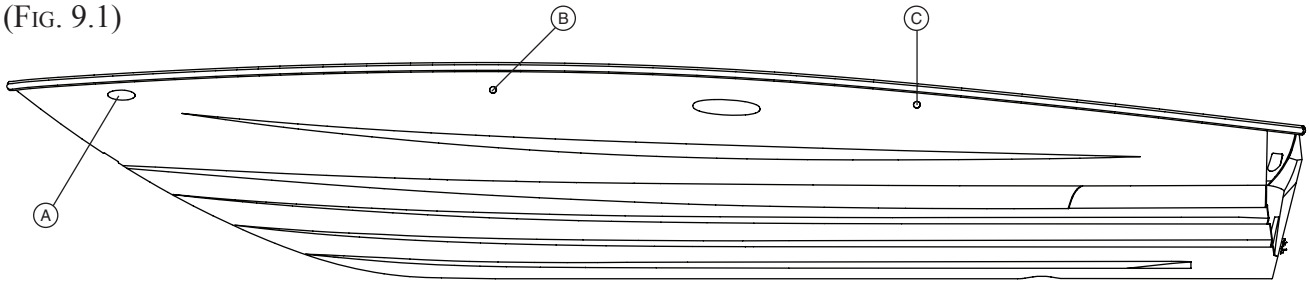

- (A) PORT DOCKING LIGHT, OPT.
- (B) WASTE PUMP OUT VENT
- (C) FUEL TANK VENT

STARBOARD THROUGH-HULL CUTOUTS
(FIG. 9.2)

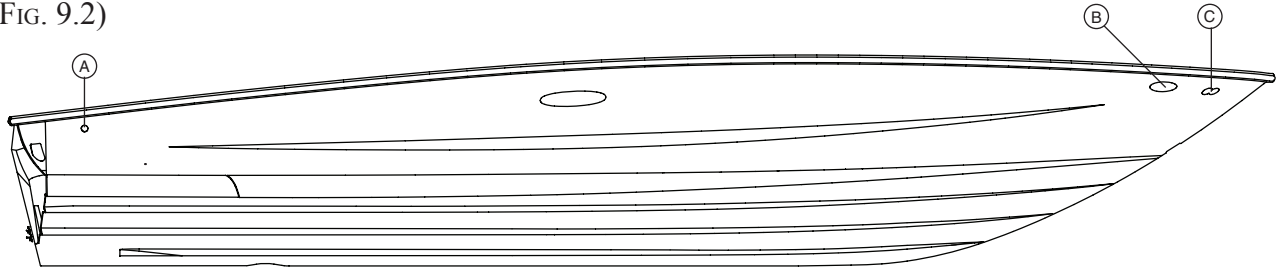

- (A) BILGE PUMP DRAIN
- (B) STBD DOCKING LIGHT, OPT.
- (C) HORN

BILGE AND TRANSOM THROUGH-HULL CUTOUTS
(FIG. 9.3)

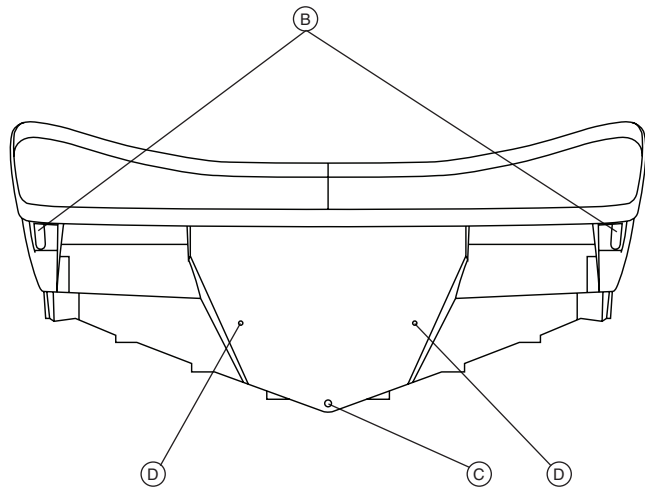
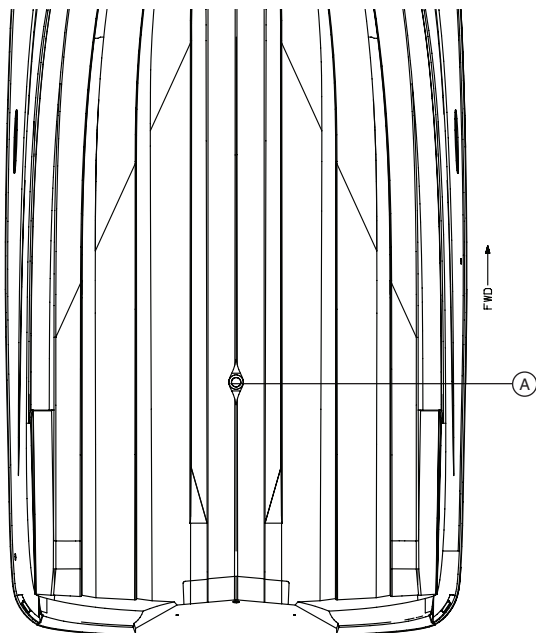

- (A) TRANSDUCER, OPT.
- (B) STERN EYE BOLTS (2 EACH, PORT & STBD)
- (C) GARBOARD DRAIN
- (D) UNDERWATER LIGHT



8. HELM, INSTRUMENT & SWITCH LAYOUT

HELM LAYOUT
(FIG. 10.1)

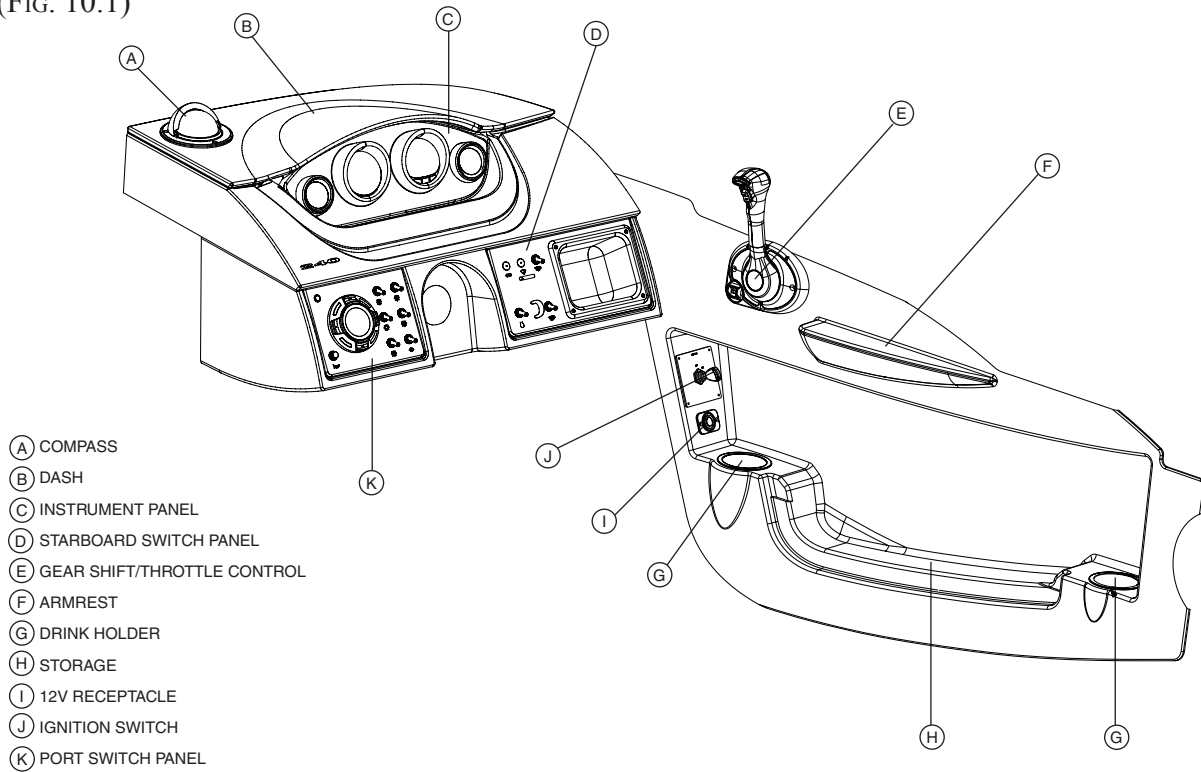

INSTRUMENT PANEL
(FIG. 10.2)

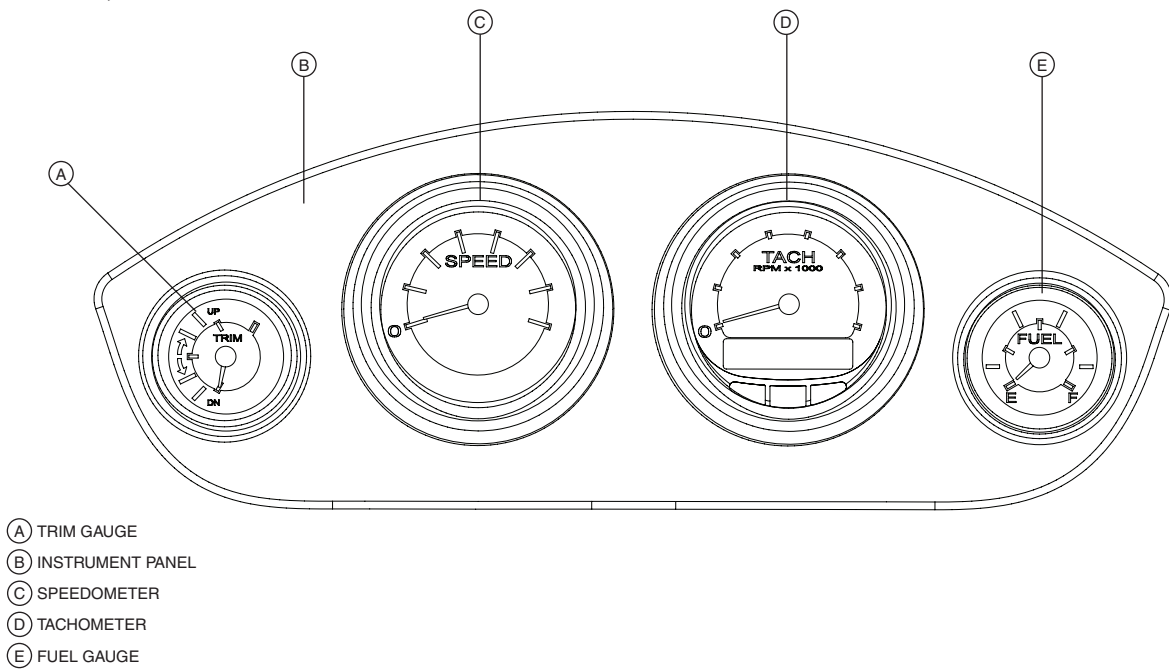

240 SUNDECK OWNERS MANUAL

SWITCH PANEL, STARBOARD
(FIG. 11.1)

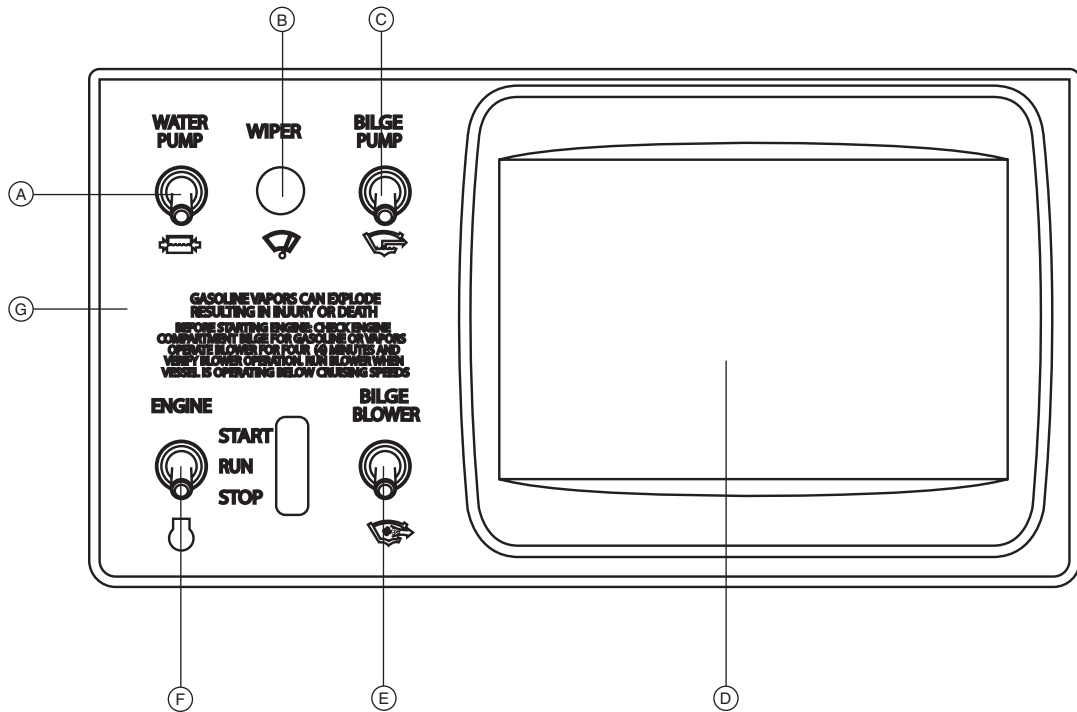

- (A) WATER PUMP
- (B) WIPER
- (C) BILGE PUMP
- (D) STORAGE BIN
- (E) BILGE BLOWER
- (F) IGNITION SWITCH
- (G) SWITCH PANEL

SWITCH PANEL, PORT
(FIG. 11.2)

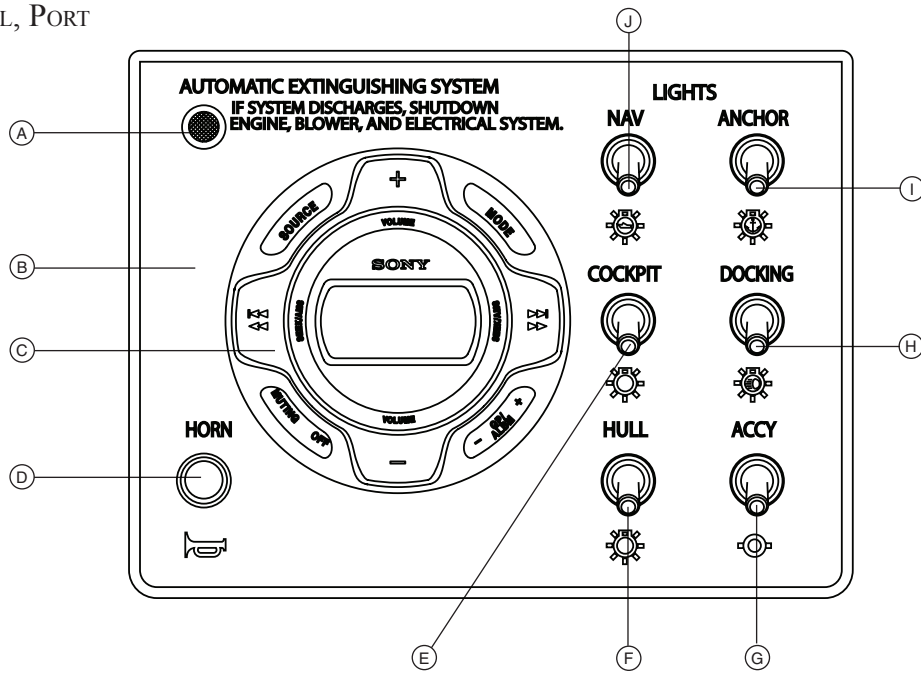

- (A) AUTOMATIC FIRE EXTINGUISHING SYSTEM INDICATOR
- (B) SWITCH PANEL
- (C) STEREO REMOTE
- (D) HORN
- (E) COCKPIT LIGHTS
- (F) HULL LIGHTS
- (G) ACCESSORY
- (H) DOCKING LIGHTS
- (I) ANCHOR LIGHT
- (J) NAV LIGHTS



9. DECK LAYOUT

DECK LAYOUT
(FIG. 12.1)

- (A) ANCHOR LOCKER
- (B) PORT NAVIGATION LIGHT
- (C) BOW SEATING
- (D) BOW STORAGE
- (E) WASTE PUMP OUT
- (F) COCKPIT STORAGE
- (G) PORT HELM SEATING
- (H) AFT COCKPIT SEATING
- (I) DRINK HOLDERS
- (J) SWIM PLATFORM
- (K) SWIM LADDER
- (L) SUNPAD
- (M) TRANSOM STORAGE
- (N) TRANSOM DOOR
- (O) STARBOARD HELM SEAT
- (P) STEERING WHEEL
- (Q) FRESH WATER FILL
- (R) COOLER
- (S) STARBOARD NAVIGATION LIGHT

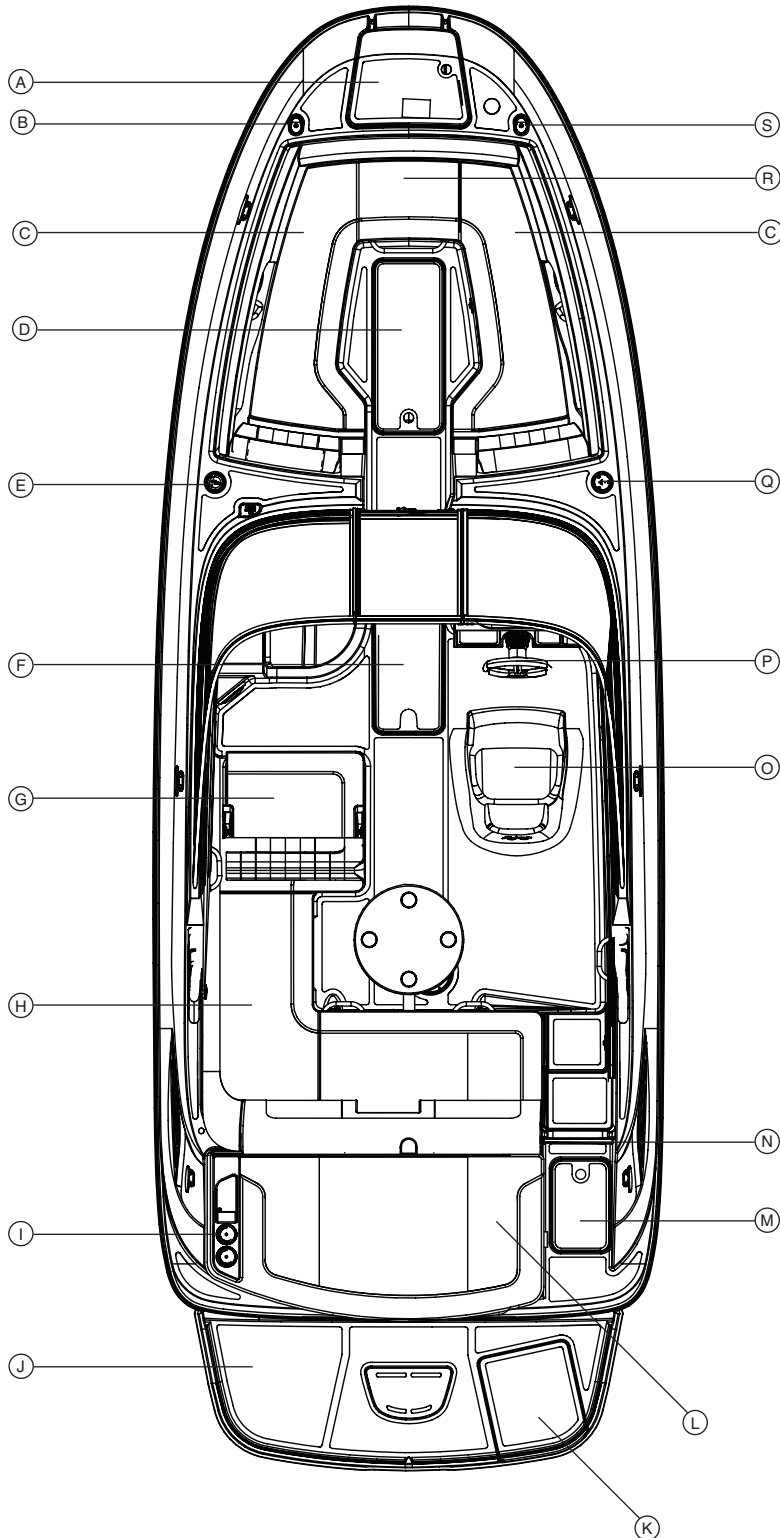

10. CLEATS/LIFTING/STORAGE

Cleats must not be used for lifting the boat; they are intended for docking or mooring use only.

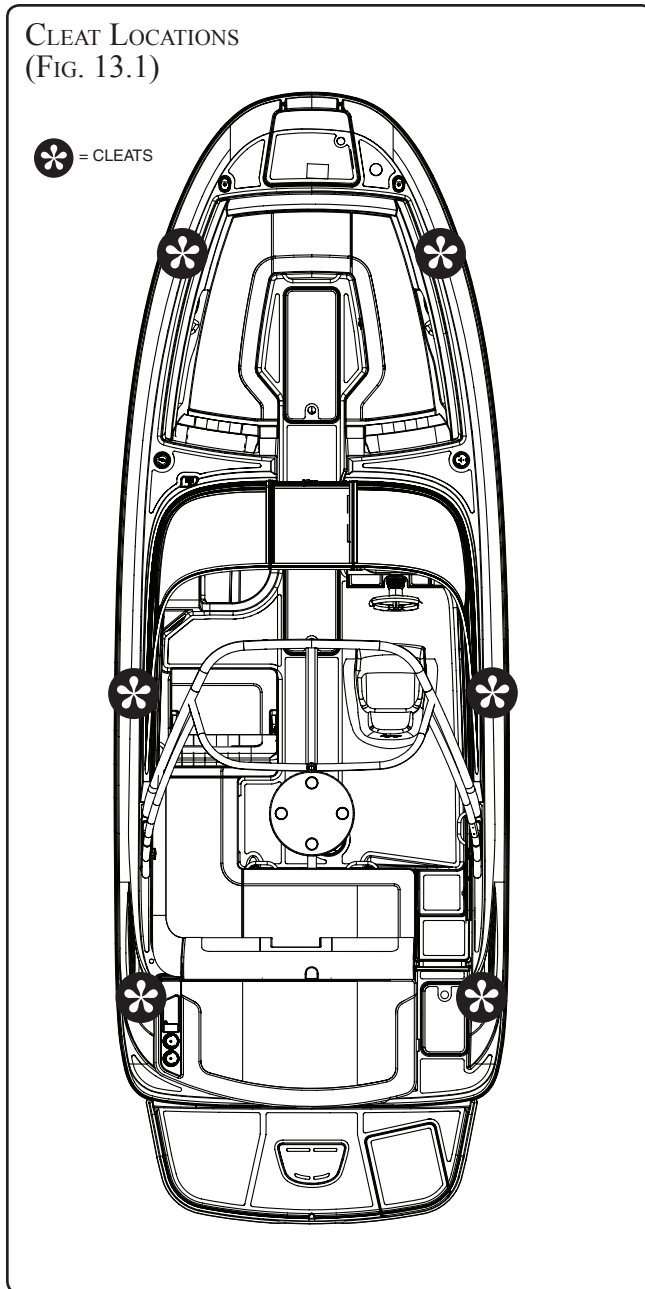

BOW AND STERN EYES: The bow eye must be used to haul the boat onto a trailer. The stern eyes must be used as tie down points for trailering the boat. The bow and stern eyes may be used for short term lifting of the boat such as for service. Long term lifting with the bow and stern eyes may cause stress on the fiberglass and gel coat.

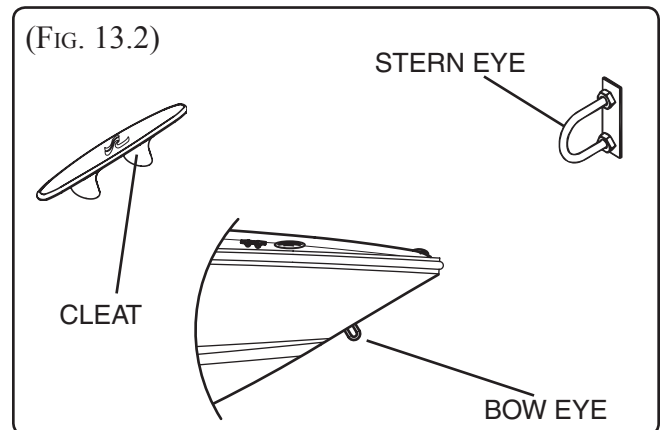

For long term storage, use flat, wide belt-type slings and spreaders long enough to keep pressure from gunwales. With fiberglass boats, severe gelcoat crazing or more serious hull damage can occur during launching and hauling if pressure is created on the gunwales by the slings. Cable-type slings should be avoided. Do not place the slings where they may lift on underwater fittings. When lifting the boat always keep the bow higher than the stern to drain the exhaust lines and to prevent water from running forward through the manifold and into the engine where it can become trapped. It may seem expedient to lift only the stern when changing a propeller, but this can result in water entering the engine cylinders, causing hydrostatic lock and resulting in possible engine failure. Even a small amount of water in the engine can cause rust and is to be avoided.

Never hoist the boat with an appreciable amount of water in the bilge. Fuel and water tanks should preferably be empty, especially if of large capacity.

11. NAVIGATION AND ANCHOR LIGHTS

NAVIGATION AND ANCHOR LIGHTS
(FIG. 14.1)

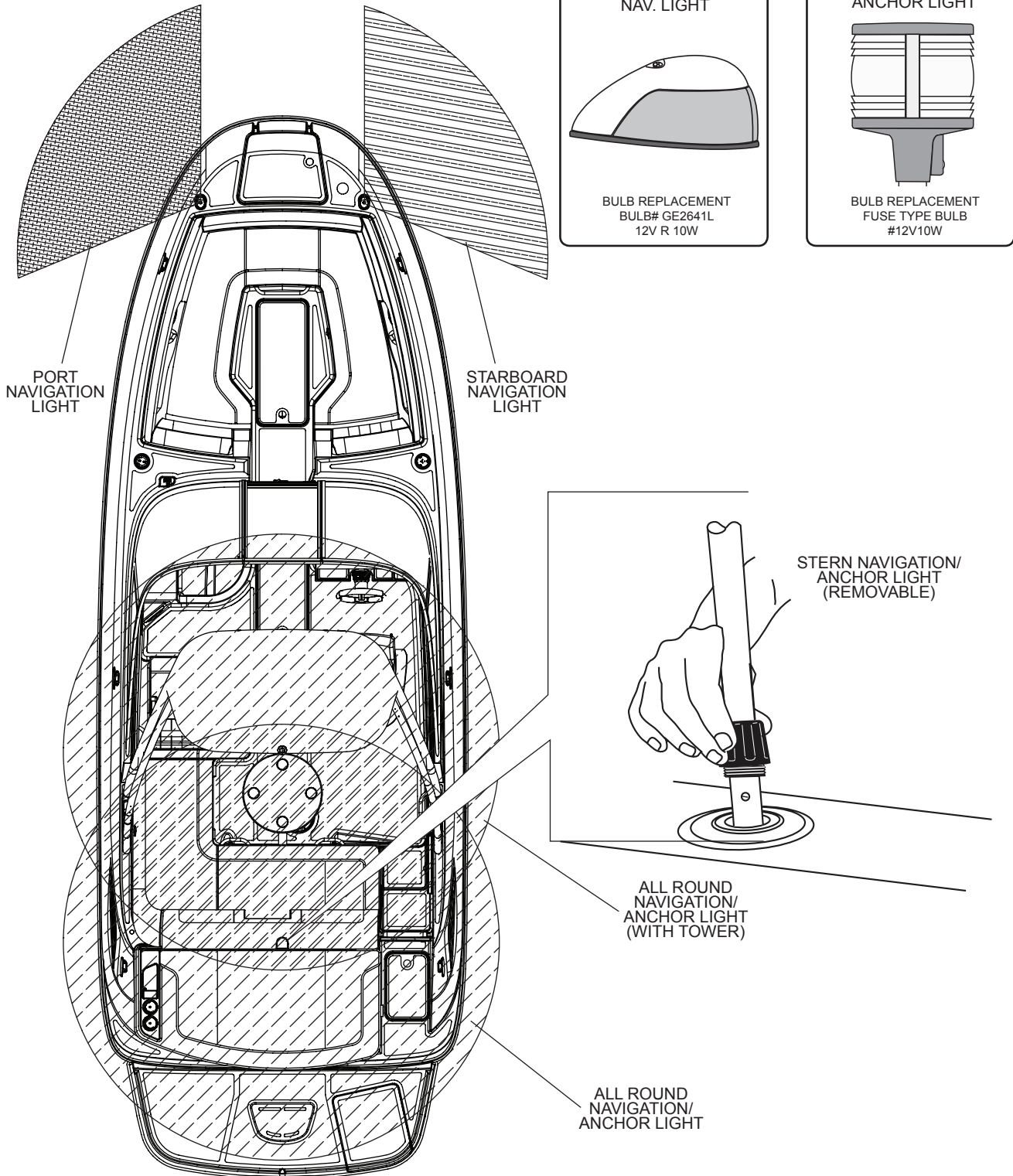

12. BILGE

BILGE LAYOUT
(FIG. 15.1)

- (A) PORT COCKPIT DRAIN
- (B) FUEL TANK
- (C) STARBOARD COCKPIT DRAIN
- (D) BILGE PUMP (1100 GPH) AND FLOAT SWITCH
- (E) FIRE EXTINGUISHING SYSTEM
- (F) TRIM TAB PUMP
- (G) STEERING LINES
- (H) ENGINE MOUNTS
- (I) FUEL FILL
- (J) BLOWER AND HOSES
- (K) BATTERY ASSEMBLY
- (L) FUEL TANK VENT

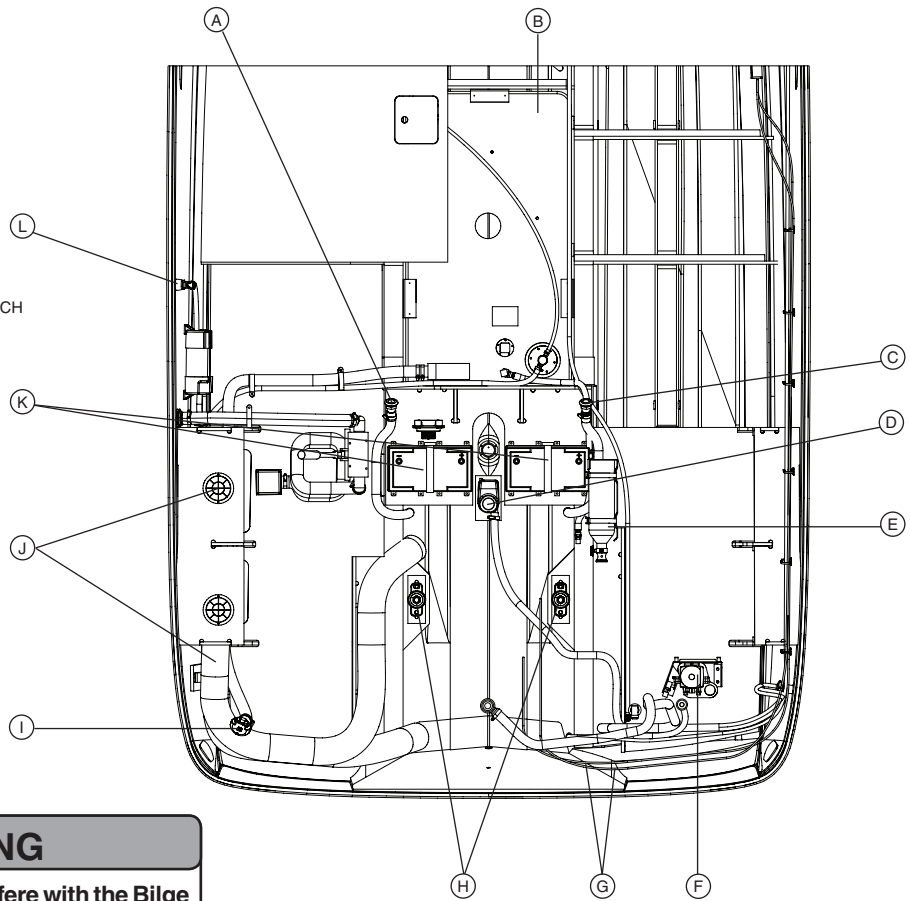

! WARNING

Do not allow obstructions to interfere with the Bilge Blower or Ventilation Intake operation. Engine(s) performance may be adversely affected.

TYPICAL BILGE BLOWER
(FIG. 15.2)

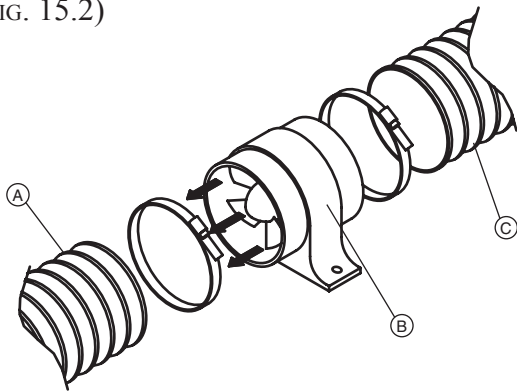

- (A) HOSE TO EXTERIOR
- (B) BILGE BLOWER
- (C) HOSE FROM BILGE

TYPICAL BILGE PUMP AND FLOAT SWITCH
(FIG. 15.3)

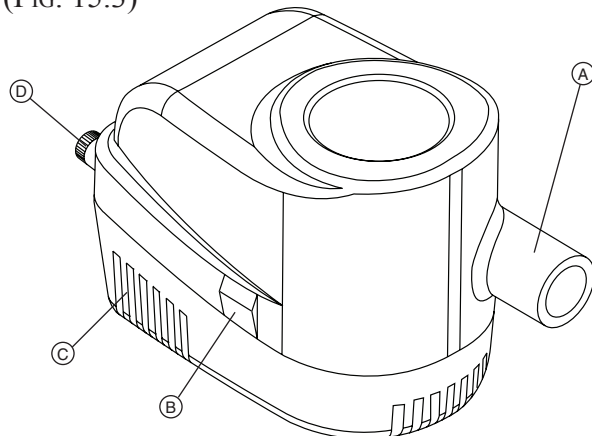

- (A) WATER OUTLET
- (B) LOCK TAB
- (C) FILTER W/ INTEGRATED FLOAT SWITCH
- (D) KNOB TO MANUALLY TEST FLOAT SWITCH AND PUMP



13. ENGINES

The engines are the heart of your Sea Ray Sport Boat. Proper attention to and maintenance of your engines will assure you of many hours of pleasurable, safe boating and will prevent unnecessary engine problems. Sea Ray® strongly urges you to fully comply with the manual provided by the engine manufacturer. Follow the recommended maintenance and warranty schedule in your Engine Operator's Manual included in the owner's package.

REFER TO THE ENGINE OWNER'S MANUAL FOR OPERATING INSTRUCTIONS AND WARRANTY INFORMATION.

The engines are warranted directly by the engine manufacturer, not by Sea Ray®.

The propulsion system on your boat is a conventional stern drive systems.

STERN DRIVE SYSTEM

A stern drive propulsion system, also known as an inboard-outboard engine, has the engine inside the boat secured to the hull's stringers at the rear end of the hull. The stern drive unit, also called the outdrive, attaches to the outside of the hull or transom. The stern drive unit pivots to steer the boat.

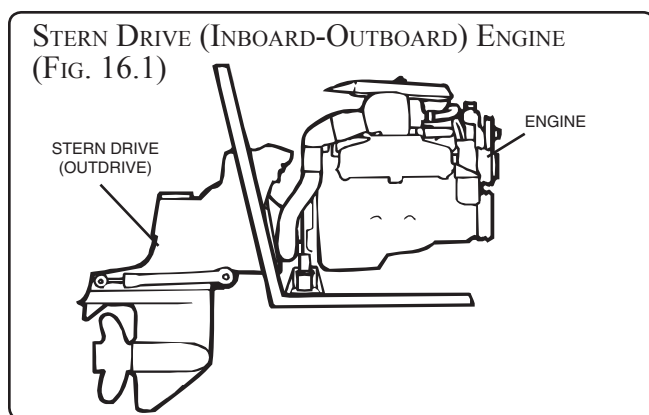

14. FUEL SYSTEM

A. GASOLINE FUEL SYSTEM

The gasoline fuel system on your 240SD consists of a 58 gallon (219 liter) fuel tank, fuel tank vent, anti-siphon valve, engine fuel supply line and fuel fill. Your vessel contains a new EPA certified fuel system. The system prevents spit back when filling the tank and lowers the out gassing emissions through the tank and vent.

B. CARBON CANISTER VENTING SYSTEM

Sea Ray Sport Boats are equipped with a carbon canister. This canister filters all the hydrocarbons that pass through the canister. If the carbon canister is mounted in the engine compartment, the canister will have a heat shield. Periodically check that the shield has not become damaged.

C. FUEL VENT

Sea Ray® Sport Boats are equipped with a fuel tank vent for each tank which serves as a pressure/vacuum release. The thru-hull fitting (diesel option) has a flame arrester, making it imperative that you keep the screen clean and in excellent repair. Replace the screen immediately if it becomes damaged or displaced. Periodically check the vents to assure that they are not clogged.

! CAUTION

Never start an engine until you are certain that fuel fumes are not present in the engine compartment or elsewhere in the boat.

FUEL RECOMMENDATIONS

The quality of the fuel is very important for satisfactory engine performance and long engine life. Care should be taken to select fuels having the octane rating recommended for the engine, as indicated in the owner's manual, for proper operation. Fuel should be clean and free of contamination. Your fuel tanks should be kept full of fuel whenever possible. This will reduce the amount of water condensation and reduce the possibility of contamination.

240 SUNDECK OWNERS MANUAL

When filling the tank, do NOT attempt to top off the tank. When the fill nozzle shuts off, the tank is full. Continuing to fill past the fuel fill shut off will cause the system to spit back.

NOTICE

GASOLINE RECOMMENDATIONS

Minimum octane rating of 87 AKI.

The use of improper gasoline or additives can damage your fuel system and is considered misuse of the system. Damage caused by improper gasoline or additives WILL NOT be covered under warranty.

ETHANOL-BLENDED FUELS

Ethanol is an oxygenated hydrocarbon compound that has a high octane rating and therefore is useful in increasing the octane level of unleaded gasoline.

The fuel-system components of your Mercury engine(s) have been tested to perform with the maximum level of ethanol blended gasoline (10% ethanol) currently allowed by the EPA in the United States.

Special precautions should be considered with the use of fuel containing ethanol in your system. Fuels with ethanol can attack some fuel-system components, such as tanks and lines, if they are not made from acceptable ethanol compatible materials. This can lead to operational problems or safety issues such as clogged filters, leaks or engine damage.

Your boat was manufactured, and shipped from the factory, with ethanol-compatible materials. Before introducing gasoline with ethanol into your fuel tank, ask your dealer if any components have been added or replaced that are not recommended by Sea Ray®, Mercury or may not be ethanol-compatible.



CAUTION

The use of fuels containing ethanol higher than 10 present (E-10) can damage your engine and/or fuel system and will void the warranty.

E-85 FUELS COULD SERIOUSLY DAMAGE YOUR ENGINES AND MUST NEVER BE USED.

FILLING THE TANK

It is best to maintain a full tank of fuel when the engine is not in use. This will reduce air flow in and out of the tank due to changes in temperature as well as limiting exposure of the ethanol in the fuel to humidity and condensation.

PHASE SEPARATION

Humidity and condensation create water in your fuel tank which can adversely effect the ethanol blended fuel. A condition called phase separation can occur if water is drawn into the fuel beyond the saturation point. The presence of water in the fuel beyond the saturation level will cause most of the ethanol in the fuel to separate from the bulk fuel and drop to the bottom of the tank, significantly reducing the level of ethanol in the fuel mixture in the upper level (phase). If the lower level (phase), consisting of water and ethanol, is deep enough to reach the fuel inlet it could be pumped directly to the engine(s) and cause significant problems. Engine problems can also result from the reduced ethanol/fuel mixture left in the upper phase of the tank.

ADDITIVES

There is no practical additive known that can prevent or correct phase separation. The only solution is to keep water from accumulating in the tank.

If phase separation does occur, your only remedy is to drain the fuel, clean and dry the tank completely and refill with a fresh, dry load of fuel.

FUEL FILTERS

Mercury already provides the appropriate level of filtration to protect the engine from debris. The addition of another in-line filter to the system will create a possible flow restriction that can starve the engine(s) of fuel. As a precaution, it is advisable to carry extra on-engine filters in case filter plugging from debris in the fuel tank becomes a problem during boating.



240 SUNDECK OWNERS MANUAL

MAINTENANCE

Periodically inspect for the presence of water in the fuel tank. If any is found, all water must be removed and the tank completely dried before refilling the tank with any fuel containing ethanol.

STORAGE

Long periods of storage and/or non-use, common to boats, create unique problems. When preparing to store a boat for extended periods, of two months or more, it is best to completely remove all fuel from the tank. If it is not possible to remove the fuel, maintaining a full tank of fuel with a fuel stabilizer added to provide fuel stability and corrosion protection is recommended.

REFER TO THE ENGINE MANUFACTURER'S MANUAL IN YOUR OWNER'S MANUAL PACKAGE FOR COMPLETE INSTRUCTIONS AND WARRANTY INFORMATION.



240 SUNDECK OWNERS MANUAL

FUEL SYSTEM
(FIG. 19.1)

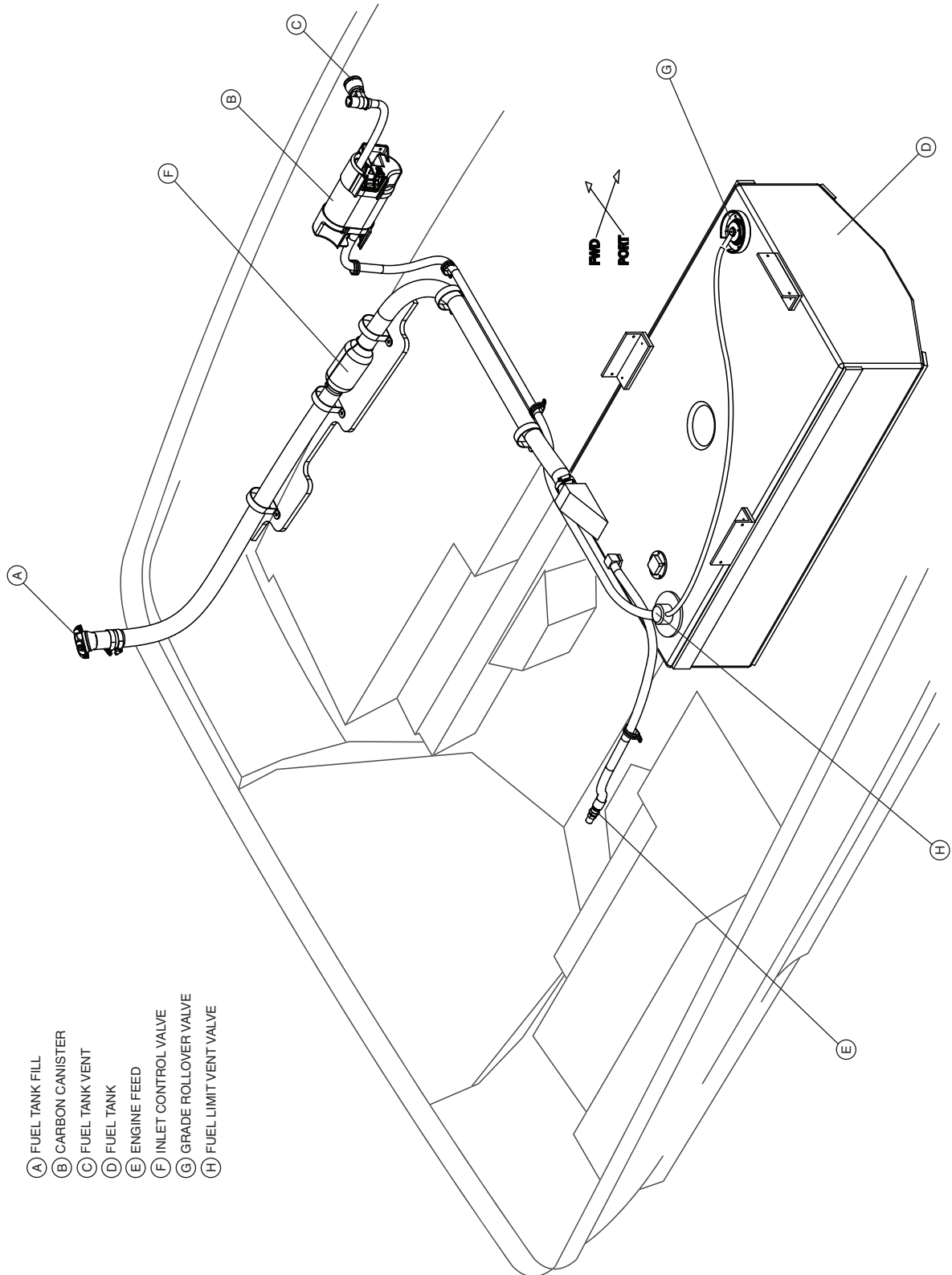

- (A) FUEL TANK FILL
- (B) CARBON CANISTER
- (C) FUEL TANK VENT
- (D) FUEL TANK
- (E) ENGINE FEED
- (F) INLET CONTROL VALVE
- (G) GRADE ROLLOVER VALVE
- (H) FUEL LIMIT VENT VALVE



15. WATER SYSTEM

WATER SYSTEM
(FIG. 20.1)

- (A) TRANSOM WASHDOWN
- (B) FRESH WATER FILL
- (C) FRESH WATER PUMP
- (D) ANCHOR LOCKER WASHDOWN

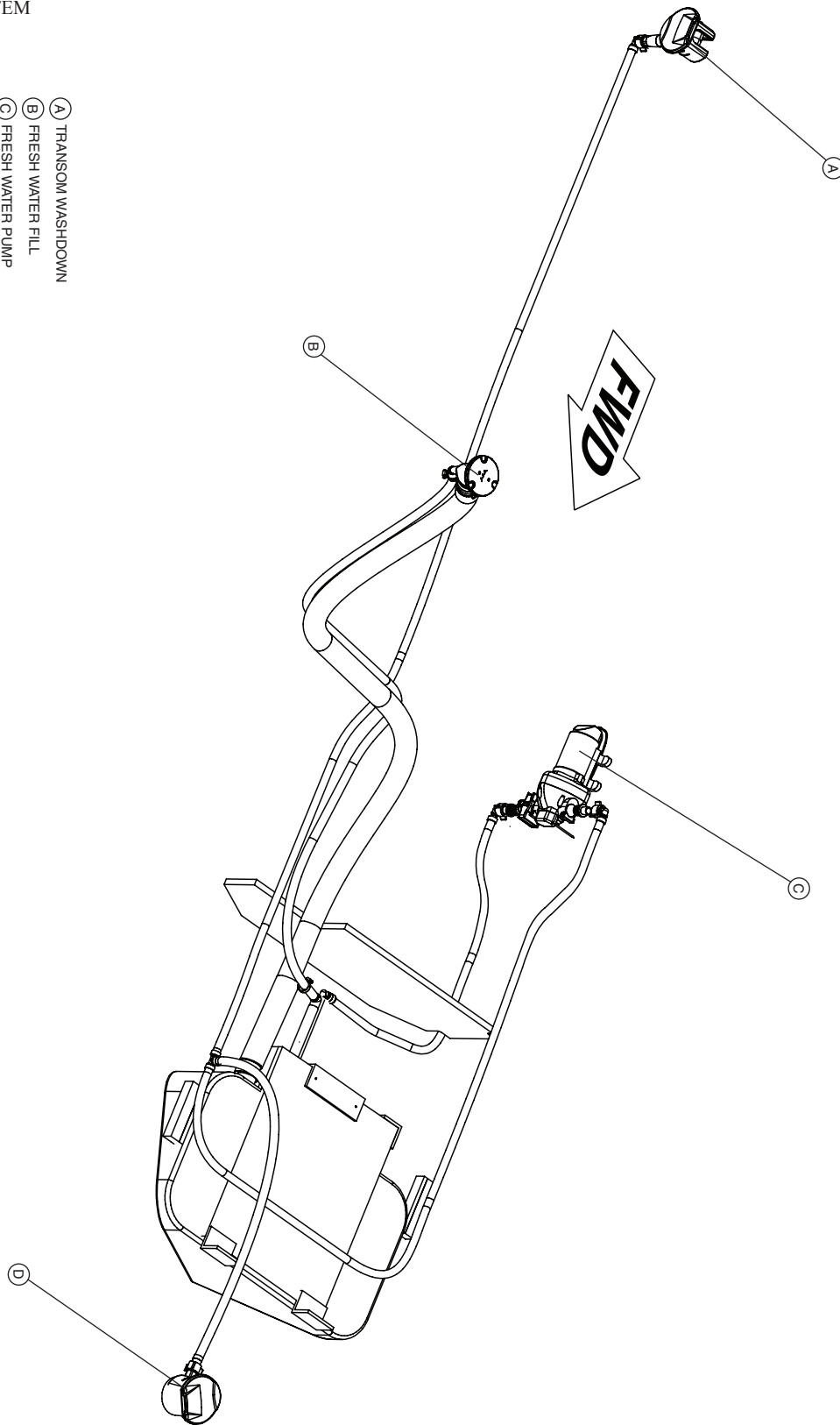

16. AUTOMATIC FIRE EXTINGUISHER SYSTEM

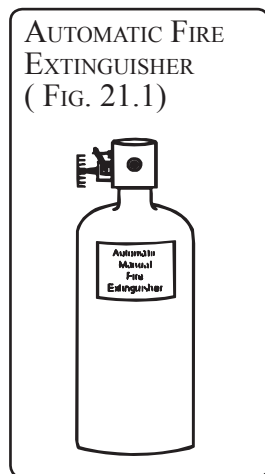

Your boat may be equipped with an automatic fire extinguisher system located aft of the engine. In the event of a fire, the heat sensitive automatic head will release the extinguishant as a vapor, totally flooding the area in fire-killing concentrations.

IF ACTUATION OCCURS, IMMEDIATELY SHUT DOWN ALL ENGINES, POWERED VENTILATION, ELECTRICAL SYSTEMS

AND EXTINGUISH ALL SMOKING MATERIALS. DO NOT IMMEDIATELY OPEN THE ENGINE COMPARTMENT!! THIS FEEDS OXYGEN TO THE FIRE AND FLASHBACK COULD OCCUR.

Allow the extinguishant to “soak” the compartment for at least fifteen (15) minutes and for hot metals or fuels to cool before cautiously inspecting for cause of fire. Have portable extinguishers at hand and ready. Do not breathe fumes or vapors caused by the fire.

A. GASOLINE ENGINE BOATS

AUTOMATIC FIRE EXTINGUISHER INDICATOR LIGHT (FIG. 21.2)

AUTOMATIC EXTINGUISHER SYSTEM

1. LIGHT ON-UNIT CHARGED
2. LIGHT OFF-UNIT DISCHARGED
3. IF SYSTEM DISCHARGES. SHUT DOWN ENGINE(S), BLOWERS AND ELECTRICAL SYSTEMS

The system indicator light is wired to the ignition and is turned ON when the ignition is turned ON. The indicator light, located at the helm, indicates to the helmsman when the unit has discharged. Under normal circumstances, when the ignition is ON the charge indicator light is ON. If the unit discharges, the light will go OFF.

B. MANUAL FIRE EXTINGUISHING SYSTEM PULL HANDLE (IF EQUIPPED)

Located at the helm, the manual fire extinguisher system allows the operator to manually activate the automatic extinguisher in the engine room. Early detection and use of the manual override system will reduce fire damage by eliminating the time necessary for heat in the engine room to rise to a temperature necessary to activate the automatic fire extinguisher.

TO OPERATE:

1. Pull pin securing the handle.
2. Pull red FIRE handle quickly and briskly.

D. SAFETY PIN

The safety pin is used on boats equipped with the Manual Fire Extinguishing System Pull Handle. The safety pin, located at the neck of the extinguisher bottle in the engine room is for shipping and transfer of the bottle only. The pin **MUST** be removed in order to manually operate the system.

MANUAL FIRE EXTINGUISHING SYSTEM PULL HANDLE (FIG. 21.3)

TO MANUALLY ACTIVATE THE ENGINE ROOM FIRE EXTINGUISHER:

1. PULL PIN
2. PULL HANDLE

located at the helm



ENGINE ROOM FIRE EXTINGUISHER
(FIG. 22.1)

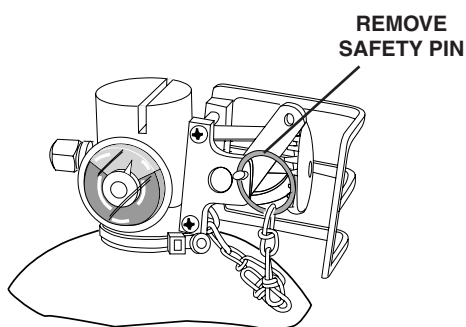

NOTE: THE MANUAL SYSTEM WILL NOT OPERATE
IF SAFETY PIN IS INSTALLED.

17. ENTERTAINMENT SYSTEM

The 12 volt AM/FM radio single CD stereo is located in the port glove box.

The system includes four (4) splash proof speakers, a subwoofer, a digital remote control located at the control station and an optional remote on the transom. An optional speaker system is available with the Water Sports Tower option.

18. CANVAS

The optional canvas package consists of:

- Bimini Top w/ Boot
- Front Curtains
- Side Curtains
- Aft Curtain
- Canvas Storage Bag
- Cockpit Cover
- Tonneau Cover

The Canvas Cockpit Cover w/ Tonneau is also available as an individual option as well as a Forward Bow Bimini Top w/ Boot.

240 SUNDECK ELECTRICAL SYSTEM

The 12 volt direct current (DC) electrical system (similar to that in your car or truck) derives its power from the batteries. Batteries are kept charged by the engine-driven alternator or the optional battery charger/converter which must be powered by shore power. The battery voltage is indicated by the voltmeter on the helm panel (on the SmartCraft™ System Tach) and if equipped with optional shorepower, on the battery charger panel located in the bilge. The batteries supply power to the fuses in the engine compartment, or the circuit breakers on the main DC breaker panel. This panel contains the breakers which supply power to the subpanels and fuse blocks at the control station.

The negative terminal of each bank of batteries is attached to the negative ground studs of the propulsion engines. This "negative ground system" is the approved system for marine DC electrical systems.

Ask your dealer for a careful analysis of DC power needs on your boat. It may be necessary to add batteries or auxiliary charging methods to supply adequate power for any additional accessories you wish to install.

! DANGER
DO NOT USE JUMPER CABLES IN THE ENGINE COMPARTMENT.
They can cause an explosion from sparks.

! DANGER
A battery will explode if a flame or spark ignites the free hydrogen given off during charging.
Never use an open flame or strike sparks in the battery area.

1. BATTERIES

The batteries installed in your boat have been selected for their ability to furnish starting power based on engine starting requirements, as well as their ability to power the DC accessories attached to the electrical system.

The following tables describe the recommended marine batteries to install in your boat. All batteries in a battery bank should be of the same type, age, and rating.

Standard:

Application	Volts	CCA	RC	QTY
1 st Battery	12	800	180	1
2 nd Battery (opt)	12	800	180	1

The battery trays and battery cabling installed at the manufacturing facility will indicate the quantity of the batteries needed in your boat. Installing the minimum size battery listed above will insure that the battery bank will be sized appropriately.

COLD CRANKING AMPS (CCA) - a rating used in the battery industry to classify a battery's ability to start an engine in cold temperatures. The rating is the number of amps a fully charged battery can deliver at 0° Fahrenheit for 30 seconds, while maintaining a voltage of at least 7.2 volts, for a 12 volt battery.

RESERVE CAPACITY (RC) - is a battery industry rating, defining a battery's ability to power a vehicle with out a charging device to replenish the battery. The rating is the number of minutes a battery at 80° Fahrenheit can be discharged at 25 amps and maintain a voltage of 10.5 volts for a 12 volt battery.

BATTERY BANK - one or more batteries connected together in series or parallel to provide the sufficient Cold Cranking Amps or Reserve Capacity needed to meet engine and calculated boat loads.

! CAUTION
To prevent arcing or damage to the alternator, always disconnect battery cables before doing any work on the engine's electrical system.



240 SUNDECK ELECTRICAL SYSTEM

A. TO REMOVE THE BATTERY CABLES:

1. Turn off all items drawing power from the battery.
2. If equipped, turn off the "converter" breaker at the main distribution panel or unplug the on-board charger from the AC.
3. Turn the battery switch to the OFF position (Battery switch is optional equipment on some models).
4. Remove the negative cable first, then the positive cable.
5. With a clean rag, remove grease and dirt from the top surface of the battery.
6. To replace the cables, first replace the positive cable, then the negative.

B. BATTERY MAINTENANCE

- Check the fluid levels in the cells approximately every 4 weeks, and weekly in summer and hot zones.
- The fluid level must be between the lower and upper markings.
- Replenish only with distilled water. Do not use metal funnel.
- Coat battery terminal clamps with silicone grease. Keep battery clean and dry.

Battery life is shortened if it is drained to 20 percent (11.6v) charge before recharging, or if left in a discharged state (less than 12.4v) for days. It is recommended that a battery not be discharged more than 50 percent (approx. 12.2v). If the battery does become run down, recharge it as soon as possible.

Running the engine to recharge the battery may not be effective. The alternator only creates charging power at higher engine speeds, so simply idling or trolling will not generate enough power to recharge the battery.

If you need to charge a battery, use only a battery charger designed to charge automotive/marine batteries. Use charger only when battery is disconnected from the boat's electrical circuit. Follow the charger instructions.

If the boat is equipped with dockside power and an AC/DC converter/battery charger, keep it on when shore power is available. This will keep the batteries properly charged and allow use of the DC powered equipment on board without draining the battery.

If the boat is equipped with an on-board battery charger option, keep it plugged in when the boat is not in use and it will automatically maintain the battery. Disconnection of the battery is not necessary with an on-board, pre-wired battery charger.

C. LONG TERM BATTERY STORAGE & MAINTENANCE RECOMMENDATIONS

When a boat is not going to be used for a long period of time (more than 3 weeks) then steps should be taken to ensure that the batteries are properly maintained to mitigate low voltage issues in the future.

A battery "maintainer" smart charger (available as an option on some models) should be in use anytime the boat is not operational. Primarily this is done through shore power, but a dedicated battery maintainer can be used directly to a battery if warranted (i.e., boat not equipped with shore power, shore power unavailable, etc.). Be sure the battery maintainer is matched to the battery technology in use (sealed lead acid, absorbed glass mat, etc.) and is only used on the appropriate number of batteries.

Adequate ventilation is always a consideration when batteries are being charged due to the production of O₂ and H₂ (oxygen and hydrogen), even with sealed batteries. Regardless of where the batteries are located, ensure there is sufficient ventilation where a battery is being charged.

If the boat is on a trailer, or is being hauled out and placed in dry storage, (i.e., boat rack or blocks) one should consider physically disconnecting the batteries from the boat and placing them on a maintainer. The batteries could be left in the boat but electrically disconnected from the boat if the batteries are easily accessible for maintenance, the ventilation is sufficient, and temperatures do not drop below freezing (0°C/32°F). Disconnecting the battery is not necessary if boat is equipped with an



240 SUNDECK ELECTRICAL SYSTEM

on-board battery charger and the aforementioned conditions apply.

If the boat is being placed onto a boat rack where accessibility is not possible, or the battery compartment temperatures are expected to drop well below freezing (i.e., less than -10°F), the batteries should be removed from the boat and placed in suitable dry storage with maintainers connected and adequate ventilation. While fully charged batteries can withstand hard freezing temperatures, the idea is to increase the life of the batteries by minimizing unnecessary stresses.

In all cases the battery voltage, specific gravity and the water level should be monitored periodically during storage.

D. RECOMMISSIONING

Sometimes a battery may get left off a maintainer. It is paramount to give it a full charge before attempting to embark on a voyage. Most batteries will take 48-96 hours to fully charge depending on chemistry, technology, depth of discharge, capacity of maintainer, and general health of the battery.

When preparing to restore batteries back to operation within the boat, it is paramount to test the batteries to ensure they are fully functional. There are two primary aspects to consider - State of Charge (SOC) and State of Health (SOH). A good test device will determine if a "surface charge" is giving a false indication of a good charge state. SOH is not as common as SOC but does indicate remaining useful life of the battery. A test device measures the internal resistance over a frequency range to give you a SOH reading. While it would be prudent to replace a battery if SOH is less than 50 percent, do not put a battery into service that has less than 30 percent SOH. A battery load tester is a general indicator of a battery's ability to provide a cranking current, but it is not as accurate as actual SOC and SOH readings.

Another item of consideration is the quality of the connections being made to the batteries. Inspect for corrosion and poor terminal connections (crimp, corrosion, strand breakage, etc.) prior to restoring batteries to full operation. As required, ensure battery cells have adequate electrolyte fluid levels (**use only distilled water and no metal funnels**) and use a silicone grease on the battery post terminals.

2. IGNITION PROTECTION

All electrical components in the engine compartment must be ignition-protected to avoid the possibility of creating sparks in a gasoline environment.

Protective terminal covers, such as rubber boots on electrical connections, must be in place when engine is operating or when working in the engine compartment.

 **DANGER**

GASOLINE VAPORS CAN EXPLODE

Use ONLY Marine-rated parts to replace such items as starters, distributors, alternators, generators, etc.

Do not use automotive parts for these components or any jumper cables because they are not ignition-protected and could cause a fire or explosion.

Jumper cables are not ignition-protected. DO NOT USE jumper cables in the engine compartment. The engine compartment may accumulate dangerous explosive gasoline fumes/vapors and hydrogen gas from batteries being charged. A spark produced when connecting a jumper cable can cause an explosion.



240 SUNDECK ELECTRICAL SYSTEM

3. BATTERY SWITCH (OPTIONAL)

NOTICE

For safety and convenience the following items are not shut off by the battery switches: Bilge pumps, Sump pumps, Stereo memory, Impressed current cathodic protection, Engine control modules, and Battery charger inputs. These items need constant power to perform their task. This allows the bilge pump(s) to operate anytime excess fluid accumulates in the bilge, which can occur when the boat is docked and unattended.

The battery switch isolates all battery power to the boat, with the exception of the equipment listed in the NOTICE above. The battery switch also provides a positive disconnection of battery to protect against starter engagement and battery rundown.

If you are leaving the boat for more than two hours and the boat is not connected to shore power which is maintaining the batteries, turn the battery switch(es) to the OFF position.

CAUTION

The switch should never be turned off while the engine is running to avoid damage to the alternator. Switching between batteries should also be avoided while the engine is running unless the switch has been specially designed for this purpose

TYPICAL BATTERY SWITCH
(FIG. 26.1)

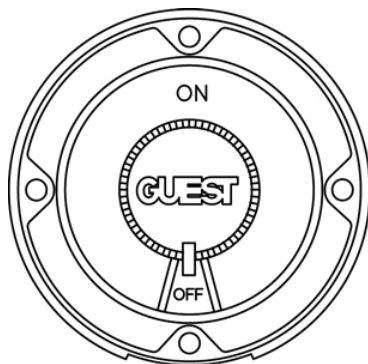

4. BATTERY SELECTOR SWITCH (OPTIONAL ON SOME MODELS)

NOTICE

The purpose of the battery selector switch is to keep one as a spare when the engine is not operating and the accessory functions, i.e.; stereo, lights, etc., are being used. If the switch is in the "BOTH" position, then both batteries are "ON" and being discharged when the engines are off. This eliminates your spare and could leave you stranded.

The battery selector switch isolates the boat from the two batteries (with the exception of the equipment listed in the NOTICE box) and switches to allow either battery or both batteries to connect to the boat's electrical systems. When not running the engines, but still using the boat, the switch should be in the ON position for one battery rather than the ON position for both batteries. This will keep one battery in the reserve should the other one be discharged. Select the battery when the engines are turned off. The battery selector switch should be in the BOTH position to connect both batteries together for starting the engine. It should remain in the BOTH position for as long as the engine is running to allow both batteries to recharge from the alternator.

BATTERY SELECTOR SWITCH
(FIG. 26.2)

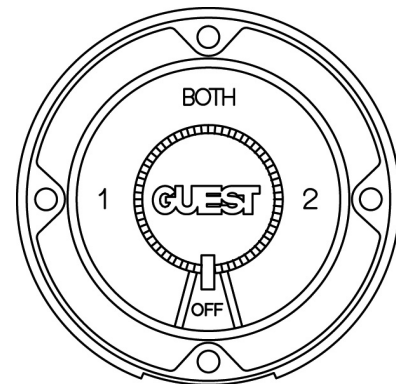

240 SUNDECK ELECTRICAL SYSTEM

5. DC POWER DISTRIBUTION

Power is fed from the batteries to the DC Breaker and fuses located in the engine compartment. These devices feed power to the Control Station Fuse Block and devices located in the bilge.

The Control Station Fuse Block powers circuits at the helm and throughout the boat.

6. FUSES AND BREAKERS

In the event it becomes necessary to replace a fuse or an electrical breaker, **REPLACE THE FUSE OR BREAKER ONLY WITH A FUSE OR BREAKER OF THE SAME RATING.** The amperage is marked on the fuse or breaker. It is recommended that you carry spare fuses and breakers. Refer to individual component user manuals for the proper fuse and breaker sizes.

If a fuse or breaker is replaced with one of lower amperage, it will not be sufficient to carry the electrical load of the equipment it is connected to and will cause nuisance failures.

Conversely, if a fuse or breaker is replaced with one of higher amperage, it will not provide adequate protection against an electrical malfunction and could create a possible fire hazard.

WARNING

Use of higher amperage fuses or breakers is a fire hazard.

Use fuses and breakers having the same amperage rating as the original or as specified.

Some of the various types of fuses and breakers used on your boat are as follows:

Fig. 27.1 is an automotive-type blade ATO/ATC fuse shown being used in an in-line fuse holder.

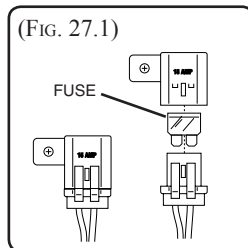
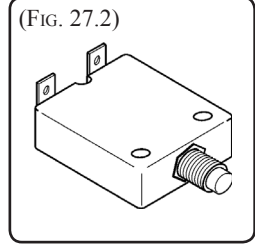
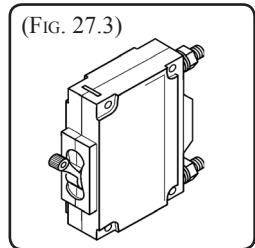

Fig. 27.2 is a thermal breaker. If it trips, the pin will pop out. Push the pin back in to reset.



Figures 27.3 and 27.4 are magnetic breakers. If they trip, the toggle or rocker will switch to the OFF position. Simply switch them back to the ON position to reset.



The cover on Fig. 27.4 protects it from accidentally being turned off. It can be turned off by inserting a small screwdriver in the slot on the rocker switch.

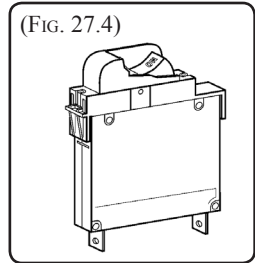

Fig. 27.5 is used to protect high amperage equipment. It is found in the bilge and cockpit. It can be reset by pressing the lever back into the slot.

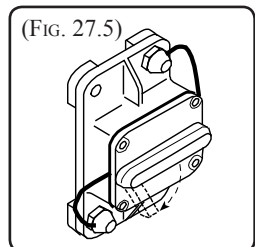
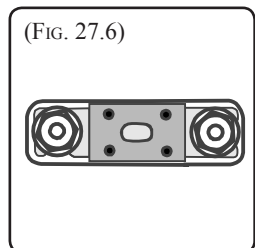

Fig. 27.6 is a current limiting ANL type and if blown must be replaced.



240 SUNDECK ELECTRICAL SYSTEM

7. PERMANENTLY INSTALLED PRE-WIRED BATTERY CHARGER (OPTIONAL)

If your boat is equipped with a permanently installed, on-board, pre-wired battery charger, it will be mounted to a bulkhead or component board on the boat, and hard-wired to the battery. The charger is designed for the marine environment and is fully automatic. The charger's AC plug will be either stowed next to it or routed to a bulkhead feed through inlet depending on the boat model. The inlet allows the plug to exit the compartment and keeps the cord from being pinched by a hatch. If the boat is not equipped with an inlet then the hatch will need to be kept open or ajar to allow the cord to exit without being pinched.

To use the on-board battery charger:

1. Plug an extension cord to the battery charger's AC cord.
2. Secure and route the extension cord to keep it from pulling at the ends and from being a trip hazard.
3. Connect the other end of the extension cord to a Ground Fault Circuit Interrupt (GFCI) protected receptacle.

Further use of this charger in regard to battery maintenance is discussed in the Battery Maintenance and the Long Term Battery Storage and Maintenance Recommendations sections of this manual.

Refer to the owner's manual package for instructions and warranty information.

WARNING

Never block air circulation through or around the unit.
Never store any gear on top of the unit.

WARNING

Never modify the charger's plug in any way. Doing so can create a shock hazard.

WARNING

Avoid serious injury or death from fire, explosion, or electrical shock.

- The battery charger must be connected to Ground Fault Circuit Interrupt (GFCI) protected receptacle.
- * When using an extension cord, connect the AC charger plug before connecting to the GFCI protected receptacle.
- Make connection in an open atmosphere free of explosive fumes.
- Make connection in a secure manner that will avoid contact with water.

8. ELECTRICAL SCHEMATICS

This owner's manual contains electrical schematics and wiring harness illustrations for your boat. These electrical schematics were generated by electrical CAD designers at the engineering division for technical reference and service technicians. Sea Ray® does not recommend that you attempt to work on the boat's electrical system yourself. Instead, we recommend that you take your boat to your authorized Sea Ray® dealer for service. Sea Ray® reserves the right to change or update the electrical system on any model at any time without notice to the consumer and is NOT obligated to make any updates to units built prior to changes.



240 SUNDECK OWNERS MANUAL

DC WIRING DIAGRAM
DRAWING NO. 09-601 (1 OF 4)
(FIG. 29.1)

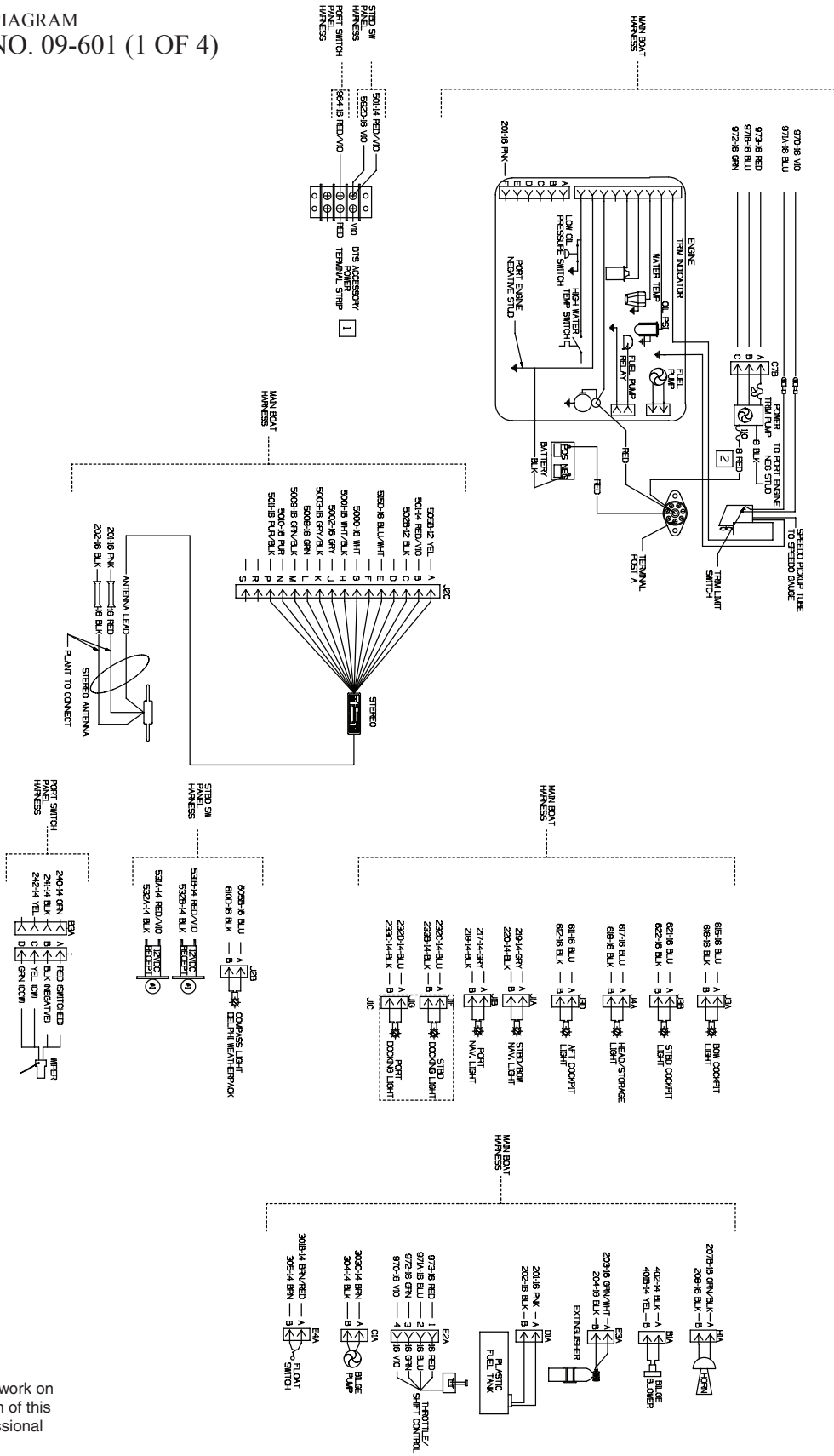

Warning:
DO NOT attempt to work on the electrical system of this boat without professional assistance.



240 SUNDECK OWNERS MANUAL

DC WIRING DIAGRAM
DRAWING NO. 09-601 (2 OF 4)
(FIG. 30.1)

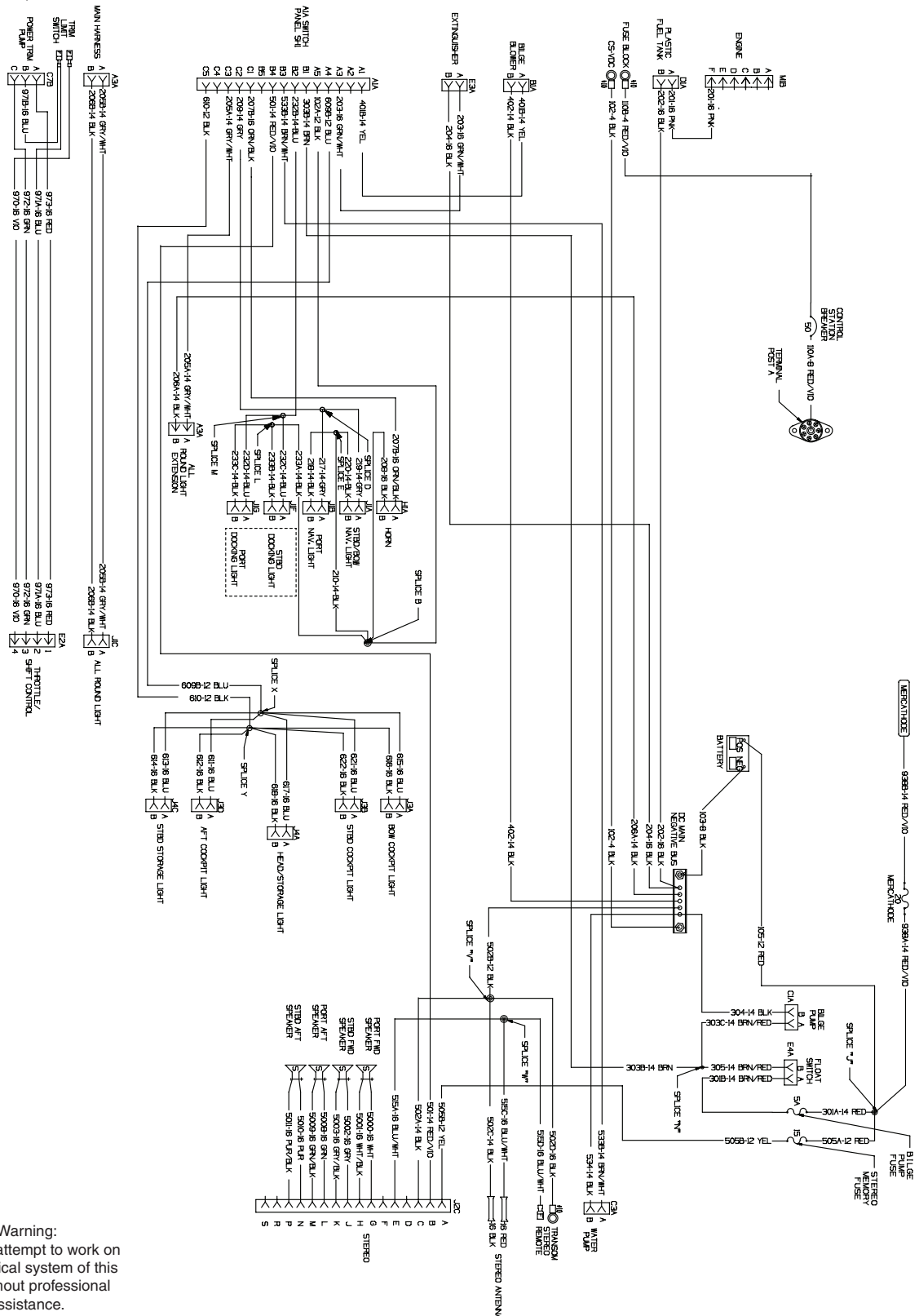

Warning:
DO NOT attempt to work on the electrical system of this boat without professional assistance.



240 SUNDECK OWNERS MANUAL

DC WIRING DIAGRAM
DRAWING NO. 09-601 (3 OF 4)
(FIG. 31.1)

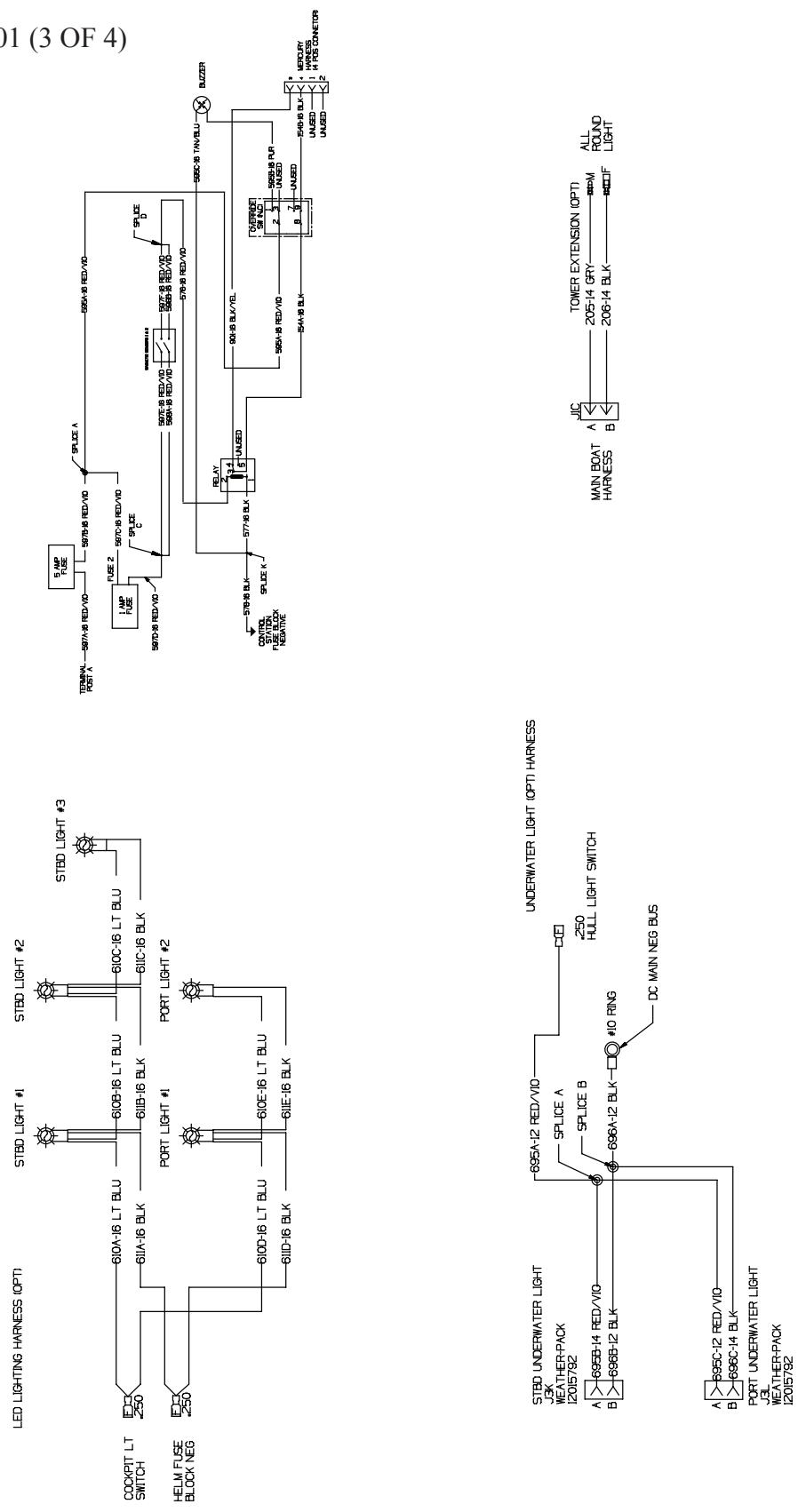

Warning:
DO NOT attempt to work on the electrical system of this boat without professional assistance.



240 SUNDECK OWNERS MANUAL

DC WIRING DIAGRAM
DRAWING NO. 09-601 (4 OF 4)
(FIG. 32.1)

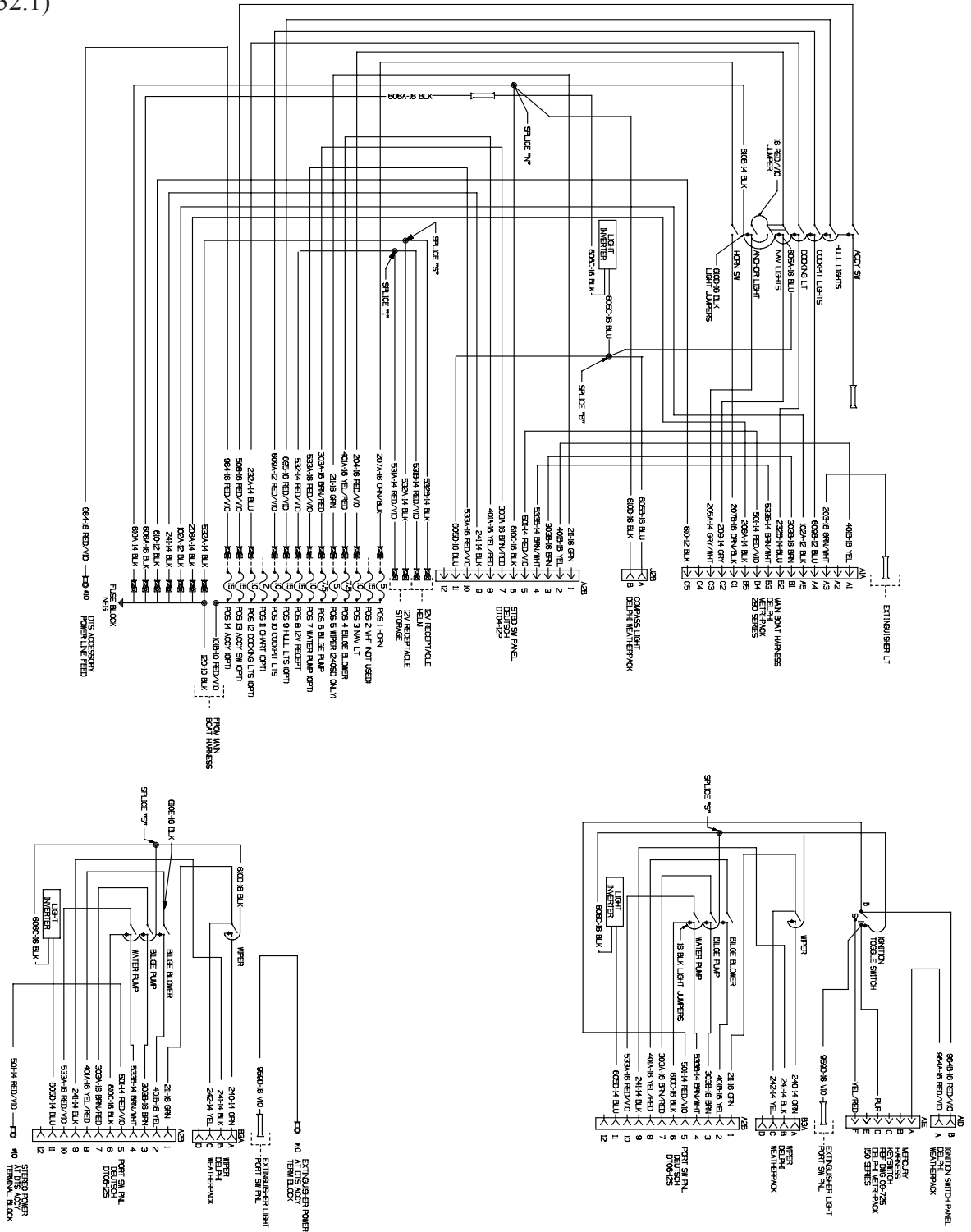

Warning:
DO NOT attempt to work on the electrical system of this boat without professional assistance.



240 SUNDECK OWNERS MANUAL

STEREO WIRING DIAGRAM
DRAWING NO. 09-601 (1 OF 1)
(FIG. 33.1)

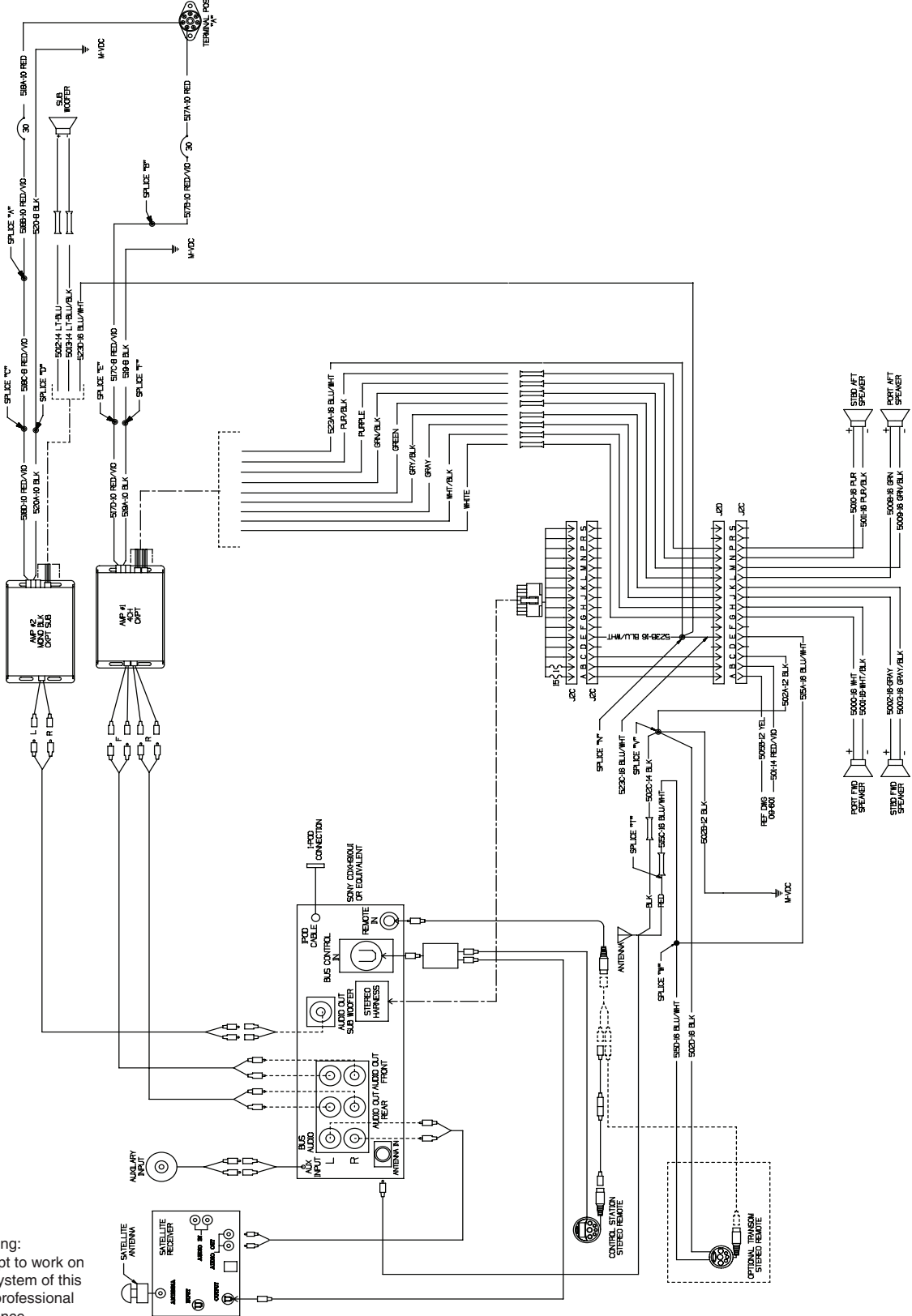

INDEX

B

Bilge Layout..... 15

C

Canvas..... 22

Capacity Plate 2

Certifications

CE (Common European) mark..... vi

NMMA (National Marine Manufacturers Assoc.) . vi

Clearances 8

D

Deck Layout..... 12

Design Category..... 4

Dimensions..... 8

E

Electrical Schematics 28

Electrical System - DC

Fuses 27

Engines..... 16

Entertainment System 22

F

Fire Extinguishing System 21

Fuel System..... 16

Fuel Recommendations 16

Fuses..... 27

H

Helm, Gauges, and Switches Layout..... 10

Hull

Identification Number (HIN)..... vi

Through-Hull Cutouts 9

I

Ignition Protection..... 25

L

Load Capacity..... 2

N

Navigation and Anchor Lights..... 14

P

Passenger Locations 1

R

Requirements

International Requirementsvii

S

Safety Labels..... 5

Safety Precautions v

Safety & Warning Labels v

Stability 1

Symbols..... 7

W

Warranties vi,viii

This publication does not contain component or accessory manuals.
Please visit www.searay.com for a complete library of all Sea Ray
Owner's and Accessory Manuals

